

PUNJAB SKILLS DEVELOPMENT FUND

Tender Document

Procurement No: 71/SYIG/PSDF/SB

SOLARIZATION OF PUNJAB SKILLS DEVELOPMENT FUND (PSDF) BUILDING, LAHORE

June 2024



Submission Date for Sealed E-Bids: July 03, 2024, on or before 03:00 PM

21 A, H-Block, Dr. Mateen Fatima Road, Gulberg II, Lahore – Pakistan.

UAN: 042-111-11-PSDF(7733) | Toll Free:0800-48627 (HUNAR) | Website: psdf.org.pk

Index of the Tender Document

SECTION-I: INVITATION TO BIDS	5
1.1 INVITATION TO BIDDERS.....	5
SECTION-II: INSTRUCTIONS TO BIDDERS (ITB)	7
2.1. INTRODUCTION.....	7
2.1.1 <i>Scope of Bid</i>	7
2.1.2 <i>Source of Funds</i>	7
2.1.3 <i>Eligible Bidders</i>	7
2.1.4 <i>Eligible Goods and Services</i>	10
2.1.5 <i>Cost of Bidding</i>	10
2.1.6 <i>One person one bid</i>	11
2.2. THE BIDDING DOCUMENTS.....	11
2.2.1 <i>Content of Bidding Documents</i>	11
2.2.2 <i>Clarification of Bidding Documents</i>	12
2.2.3 <i>Amendment of Bidding Documents</i>	14
2.3. PREPARATION OF BIDS	14
2.3.1 <i>Language of Bid</i>	14
2.3.2 <i>Bid Form</i>	14
2.3.3 <i>Bid Prices</i>	14
2.3.4 <i>Bid Currencies</i>	15
2.3.5 <i>Documents Establishing Bidder's Eligibility and Qualification</i>	15
2.3.6 <i>Documents Establishing Goods' Eligibility and Conformity to Bidding Documents</i>	16
2.3.7 <i>Bid Security</i>	18
2.3.8 <i>Period of Validity of Bids</i>	19
2.3.9 <i>Format and Signing of Bid</i>	19
2.4. SUBMISSION OF BIDS	20
2.4.1 <i>Sealing and Marking of Bids</i>	20
2.4.2 <i>Deadline for Submission of Bids</i>	22
2.4.3 <i>Late Bids</i>	22
2.4.4 <i>Modification and Withdrawal of Bids</i>	23
2.5. OPENING AND EVALUATION OF BIDS.....	24
2.5.1 <i>Opening of Bids by the Procuring Agency</i>	24
2.5.2 <i>Confidentiality</i>	26
2.5.3 <i>Clarification of Bids</i>	26
2.5.4 <i>Preliminary Examination</i>	27
2.5.5 <i>Examination of Terms and Conditions; Technical Evaluation</i>	28
2.5.6 <i>Correction of Errors</i>	28
2.5.7 <i>Conversion to Single Currency</i>	29
2.5.8 <i>Post-Qualification & Evaluation of Bids</i>	29
2.5.9 <i>Contacting the Procuring Agency</i>	30
2.5.10 <i>Grievance Redressal</i>	30
2.6. AWARD OF CONTRACT	31
2.6.1 <i>Notification of Award</i>	31
2.6.2 <i>Performance Guarantee</i>	31
2.6.3 <i>Signing of Contract/ Issuance of Purchase Order</i>	32
2.6.4 <i>Award Criteria</i>	32
2.6.5 <i>Procuring Agency's Right to Vary Quantities at Time of Award</i>	32
2.6.6 <i>Procuring Agency's Right to Accept or Reject All Bids</i>	33
2.6.7 <i>Re-Bidding</i>	33
2.6.8 <i>Corrupt or Fraudulent Practices</i>	33

2.6.9. Quantity and volume of the goods to be considered in mind	38
SECTION-III. TECHNICAL SPECIFICATIONS	39
3.1. SCOPE OF WORK.....	39
SCOPE OF WORK FOR SOLARIZATION:.....	39
MINIMUM TECHNICAL SPECIFICATIONS	42
SCOPE OF SERVICES (O&M) :	54
SECTION-IV: BID DATA SHEET	58
A. INTRODUCTION	58
B. BIDDING DOCUMENTS	59
C. BID PRICE, CURRENCY, LANGUAGE AND COUNTRY OF ORIGIN	59
D. PREPARATION AND SUBMISSION OF BIDS	60
E. OPENING AND EVALUATION OF BIDS	62
F. BID EVALUATION CRITERIA	63
G. AWARD OF CONTRACT	67
SECTION-V: GENERAL CONDITIONS OF CONTRACT	68
1. DEFINITIONS.....	68
2. APPLICATION.....	69
3.COUNTRY OF ORIGIN.....	69
4. STANDARDS.....	69
5. USE OF CONTRACT DOCUMENTS AND INFORMATION; INSPECTION AND AUDIT BY THE PROCURING AGENCY. ..	69
6. PATENT RIGHTS.....	70
7. PERFORMANCE GUARANTEE	70
8. INSPECTIONS AND TESTS	70
9. PACKING.....	71
10. DELIVERY AND DOCUMENTS	72
11. INSURANCE	72
12. TRANSPORTATION	72
13. INCIDENTAL SERVICES.....	72
14. SPARE PARTS	73
15. WARRANTY	73
16. PAYMENT.....	74
17. PRICES	74
18. CHANGE ORDERS.....	75
19. CONTRACT AMENDMENTS	75
20. ASSIGNMENT	75
21. SUB-CONTRACTS	75
22. DELAYS IN THE SUPPLIER'S PERFORMANCE.....	76
23. LIQUIDATED DAMAGES.....	76
24. TERMINATION FOR DEFAULT	76
25. FORCE MAJEURE.....	78
26. TERMINATION FOR INSOLVENCY.....	78
27. TERMINATION FOR CONVENIENCE.....	78
28. RESOLUTION OF DISPUTES	79
29. GOVERNING LANGUAGE	79
30. APPLICABLE LAW	79
31. NOTICES.....	79
32. TAXES AND DUTIES	80
SECTION-VI. SPECIAL CONDITIONS OF CONTRACT	81
SPECIAL CONDITIONS OF CONTRACT	81
1.3 Definitions (GCC Clause 1)	81
1.4 Country of Origin (GCC Clause 3)	81
1.5 Performance Guarantee (GCC Clause 7).....	81



1.6	<i>Inspections and Tests (GCC Clause 8)</i>	81
1.7	<i>Packing (GCC Clause 9)</i>	81
1.8	<i>Delivery and Documents (GCC Clause 10)</i>	81
	<i>[format of contract is to be decided by the Procuring Agency, however, a model provision for DDP is as follows]</i>	82
1.9	<i>Insurance</i>	82
	<i>(GCC Clause 11) [where applicable]</i>	82
8.	<i>Incidental Services (GCC Clause 13)</i>	82
9.	<i>Spare Parts</i>	82
10.	<i>Warranty</i>	83
12.	<i>Payment (GCC Clause 16)</i>	83
13.	<i>Prices (GCC Clause 17)</i>	84
14.	<i>Liquidated Damages (GCC Clause 23)</i>	84
15.	<i>Resolution of Disputes (GCC Clause 28)</i>	84
16.	<i>Governing Language (GCC Clause 29)</i>	85
17.	<i>Applicable Law (GCC Clause 30)</i>	85
18.	<i>Notices (GCC Clause 31)</i>	85
	<i>Section-VII. Schedule of Requirements</i>	86
7.1	SCHEDULE OF REQUIREMENTS	86
	SECTION-VIII: FORMS	87
8.1	FINANCIAL BID FORM	87
8.2	BIDDER’S JV MEMBERS INFORMATION FORM	89
8.3.	MANUFACTURER’S AUTHORIZATION FORM	90
8.4.	BIDDER PROFILE FORM	91
8.5.	GENERAL INFORMATION FORM	93
8.6.	AFFIDAVIT.....	94
8.7.	PERFORMANCE GUARANTEE FORM	95
8.8.	TECHNICAL BID FORM.....	96
	SOLARIZATION	99
8.9.	CONTRACT FORM	102
8.10.	FINANCIAL BID FORM/PRICE SCHEDULE	121
8.11.	BID SECURITY FORM	126
8.12.	PROPOSED PROGRAM OF WORKS.....	127
8.13.	METHOD OF PERFORMING WORKS	128
	SECTION IX- CHECK LIST	129

Section-I: Invitation to Bids

1.1 INVITATION TO BIDDERS

Punjab Skills Development Fund (PSDF) is the largest skills development fund in Pakistan. PSDF was established in 2010 as a not-for-profit company set up under the Companies Ordinance 1984 (now Companies Act 2017) by the Government of Punjab (GoPb). PSDF is revolutionizing the TVET sector through its innovative initiatives for vocational and technical trainings ensuring an economically bright and sustainable future for poor and vulnerable youth of Punjab.

Sealed bids/proposals are invited from established firms/companies for **“Solarization of Punjab Skills Development Fund (PSDF) Building, Lahore”** (hereafter called as bidders) to PSDF. All interested and eligible firms/companies are requested to go through the Tender document and provide relevant information along with supporting documents mentioned in this tender document and must be submitted online through e-tender portal.

						
Invitation to Bid for Hiring of a Firm / Company for “Solarization of Punjab Skills Development Fund (PSDF) Building, Lahore”						
Punjab Skills Development Fund (PSDF) is the largest skills development fund in Pakistan, established in 2010 as a not-for-profit company set up by the Government of Punjab (GoPb).						
PSDF invites bids under single stage two envelopes bidding procedure from well-reputed, experienced and tax registered firms/companies against the below-mentioned supplies. The interested firms/companies can obtain the bidding document containing all details with its evaluation criteria and terms & conditions from PSDF e-tendering portal (https://etender.psdf.org.pk/esop/guest/go/public/opportunity/current) and PPRA website (www.ppra.punjab.gov.pk)						
Sr. No.	Description	Procurement No.	Total Tenure of Contract	Bid Submission Deadline (Date & Time)	Technical Bid Opening Date & Time	Estimated Cost
1	Solarization of Punjab Skills Development Fund (PSDF) Building, Lahore	71/SYIG/PSDF/S B	One (1) Year (Extendable for another terms)	July 03, 2024 by or before 03:00 PM	July 03, 2024 on 03:30 PM	PKR 7,843,784/-
For further details, bidding documents and terms of reference, please visit: <ul style="list-style-type: none">• etender.psdf.org.pk/esop/guest/go/public/opportunity/current• PPRA website ppra.punjab.gov.pk						
Important Information: <ul style="list-style-type: none">• Bids submitted only through E-Tender Portal shall be accepted while submission by other means shall be rejected. Late Bids shall be rejected.• The Bids will be opened in the presence of the Bidders' representatives who may choose to be present at the address below on the date and time stated above.• In case of official holiday on the day of submission, next day will be treated as closing date (time of closing and opening of bid will remain the same).• The bidding procedure shall be governed strictly in accordance with the Punjab Procurement Rules						

2014 through national competitive bidding procedure.

Procurement Department, Punjab Skills Development Fund

21 A, H-Block, Dr. Mateen Fatima Road, Gulberg II, Lahore, Pakistan.

UAN: 042-111-11-PSDF(7733) | Toll Free:0800-48627 (HUNAR) | Website: psdf.org.pk

Section-II: Instructions to Bidders (ITB)

Note:- All the procurement procedures shall be conducted in accordance with Punjab Procurement Authority Act-2009 and Punjab Procurement Rules-2014, Amended till date of advertisement. In case of any conflict between the provision of this document and PPRA Act-2009/ PPRA Rules-2014, the later shall prevail.

2.1. Introduction

- 2.1.1 Scope of Bid**
- i) The Procuring Agency (PA), as indicated in the Bid Data Sheet (BDS) invites Bids for the provision of Goods as specified in the Section-IV Bid Data Sheet (BDS) and Section III - Technical Specifications & Section VII- Schedule of Requirements. The successful Bidders will be expected to deliver, install/ commissioning) the goods within the specified period and timeline(s) as stated in the BDS.
- 2.1.2 Source of Funds**
- i) The Procuring Agency named in the Bid Data Sheet has received budget from the Government of Punjab. The Procuring Agency intends to apply the provided funds/ a portion of this budget to make eligible payments under the contract for which the Invitation to bids has been issued.
- 2.1.3 Eligible Bidders**
- i) The Invitation to Bids is open to all suppliers i.e. association of firms/companies/sole proprietor/ general order suppliers/ JVs, registered with relevant Registration Authorities and Tax Departments/ Authorities (Income Tax, Sales Tax & Punjab Sales Tax etc.) [as specified in Section-IV Bid Data Sheet (BDS)], except as provided hereinafter.
 - ii) Bidders should not be associated, or have been associated in the past, directly or indirectly, with a firm or any of its affiliates which have been engaged by the Procuring Agency to provide consultancy services for the preparation of the design, specifications, and other documents to be used for the procurement of the goods to be purchased under this Invitation to Bids [if applicable].
 - iii) Government-owned enterprises may participate only if they are duly/legally authorized in this regard by the respective/relevant competent forum/authority.
 - iv) Bidders shall not be under a declaration of blacklisting by the

Procuring Agency.

- v) In the case of a Joint Venture, Consortium, or Association, all members shall be jointly and severally liable for the execution of the Contract in accordance with the terms and conditions of the Contract. The Joint Venture, Consortium, or Association shall nominate a Lead Member as nominated in the BDS, who shall have the authority to conduct all business for and on behalf of any and all the members of the joint venture, consortium, or association during the Bidding process, and in case of award of contract, during the execution of contract.
- vi) The appointment of Lead Member in the Joint Venture, Consortium, or Association shall be confirmed by submission of a valid JV or Consortium agreement to the Procuring Agency.
- vii) Any agreement that form a Joint Venture, Consortium or Association shall be required to be submitted as part of the Bid and shall be attested.
- viii) Any bid submitted by the Joint Venture, Consortium or Association shall indicate the part of proposed contract to be performed by each party and each party shall be evaluated or post qualified with respect to its contribution only and the responsibilities of each party and shall not be substantially altered without prior written approval of the Procuring Agency and in line with any instructions issued by the Authority.
- ix) The invitation for Bids is open to all prospective Supplier, Manufacturers or Authorized Agents/Dealers/Distributors subject to any provisions or licensing/regulatory requirements issued by the respective National/ Provincial Professional Statutory Body established for that particular trade or business as mentioned in bid data sheet.
- x) A Bidder shall not have a conflict of interest. All Bidders found to have a conflict of interest shall be Non-Responsive. A Bidder may be considered to have a conflict of interest with one or more parties in this bidding process, if they:
 - a) Are associated or have been associated for the procurement of the goods to be purchased under this Invitation for Bids,

directly or indirectly with a firm or any of its affiliates which have been engaged by the Procuring Agency to provide consulting services for the preparation of the design, specifications and other documents to be used.

- b) Have controlling shareholders in common; or
- c) Receive or have received any direct or indirect subsidy from any of them; or
- d) Have the same legal representative for purposes of this Bid; or
- e) Have a relationship with each other, directly or through common third parties, that puts them in a position to have access to information about or influence on the Bid of another Bidder, or influence the decisions of the Procuring Agency regarding this Bidding process; or

xii) A Bidder may be ineligible if –

- (a) The Bidder is declared bankrupt or, in the case of company or firm, insolvent;
- (b) Payments in favor of the Bidder is suspended in accordance with the judgment of a court of law other than a judgment declaring bankruptcy and resulting, in accordance with the national laws, in the total or partial loss of the right to administer and dispose of its property;
- (c) Legal proceedings are established against such Bidder involving an order suspending payments and which may result, in accordance with the national laws, in a declaration of bankruptcy or in any other situation entailing the total or partial loss of the right to administer and dispose of the property;
- (d) The Bidder is convicted, by a final judgment, of any offence involving professional conduct;
- (e) The Bidder is debarred and blacklisted due to involvement in corrupt and fraudulent practices in accordance with the provision of section 17A of PPRA Act, 2009 and Rule-21, read with Schedule appended with, Punjab Procurement Rules, 2014.
- (f) The Bidder is debarred and blacklisted in general (i.e. to the

extent of all public procurement) due to consistent performance failure in accordance with the section 17A of PPRA Act, 2009 and Rule-21, read with Schedule appended with, Punjab Procurement Rules, 2014.

(g) The firm, supplier and contractor is blacklisted/ debarred by any international organization.

- xiii) Bidders shall provide to the Procuring Agency evidence of their eligibility, proof of compliance with the necessary legal requirements to carry out the contract effectively.
- xiv) Bidders shall provide such evidence of their continued eligibility satisfactory to the Procuring Agency, as the Procuring Agency shall reasonably request.
- xv) Bidders shall submit proposals relating to the nature, conditions and modalities of sub-contracting wherever the sub-contracting of any elements of the contract amounting to more than ten percent of the Bid price is envisaged.

2.1.4. Eligible Goods and Services

- i) All goods and related services to be supplied under the Contract shall have their origin in eligible source countries, defined in the *Bid Data Sheet (BDS/Technical Specification)*, and all expenditures made under the contract will be limited to such goods and related services.
- ii) For purposes of this clause, “origin” means the place where the goods are mined, grown, or produced, or the place from which the related services are supplied. Goods are produced when, through manufacturing, processing, or substantial and major assembly of components, a commercially-recognized product is obtained that is substantially different in basic characteristics or in purpose or utility from its components.
- iii) The origin of goods and services is distinct from the nationality of the Bidder. *In any case, the requirements of Rules 10 & 26 of PPR-14, shall be followed.*

2.1.5. Cost of Bidding

- i) The Bidder shall bear all costs associated with the preparation and submission of its Bid, and the Procuring Agency named in the Bid Data Sheet, hereinafter referred to as “the Procuring Agency,” will

in no case be responsible or liable for those costs, regardless of the conduct or outcome of the Bidding process.

2.1.6. One person one bid

- i) As per Rule 36A of Punjab Procurement Rules 2014, a Bidder shall submit only one Bid in the same bidding process, either individually as a Bidder or as a member in a joint venture or any similar arrangement.
- ii) No Bidder can be a sub-contractor while submitting a Bid individually or as a member of a joint venture in the same Bidding process.
- iii) A Bidder, if acting in the capacity of sub-contractor in any Bid, shall not submit bid for the same.

2.2. The Bidding Documents

2.2.1. Content of Bidding Documents

- i) The goods required, Bidding procedures, and contract terms are prescribed in the Bidding documents. The Bidding documents, inter alia, include:
 - (a) Invitation to Bids
 - (b) Instructions to Bidders (ITB)
 - (c) Technical Specifications
 - (d) Bid Data Sheet
 - (e) General Conditions of Contract (GCC)
 - (f) Special Conditions of Contract (SCC)
 - (g) Schedule of Requirements
 - (h) Bid Form
 - (i) Manufacturer's Authorization Form
 - (j) Bidder Profile Form
 - (k) General Information Form

- (l) Affidavit
- (m) Bid Security Form
- (n) Technical Bid Form
- (o) Contract Form
- (p) Financial Bid Form / Price Schedule
- (q) Performance Guarantee Form
- (r) Check List
- (s) Integrity Pact
- (t) Proposed Program of Work
- (u) Method of Performing Works

- ii) The Bidder is required to examine all instructions, forms, terms, and specifications in the Bidding documents. Failure to furnish all information as required by the Bidding documents or to submit a Bid not responsive to the Bidding documents in every respect will be at the Bidder's risk and may result in the rejection of its Bid.
- iii) In case of discrepancies between the Invitation to Bid and the Bidding Documents listed in **ITB 2.2.1 (i)** above, the said Bidding Documents, not in conflict with any provision of PPR-14, will take precedence.
- iv) The Procuring Agency is not responsible for the completeness of the Bidding Documents and their addenda, if they were not obtained directly from the Procuring Agency or from its website or website of PPRA. Re-confirming from the Procuring Agency that all pages/ contents have been properly and clearly received is the prime responsibility of the Bidder.

2.2.2. Clarification of Bidding Documents

- i) A prospective Bidder requiring any clarification of the Bidding documents may notify the Procuring Agency in writing or by email at the Procuring Agency's address indicated in Invitation to Bid/ Tender Notice/ Advertisement. The Procuring Agency will respond in writing to any request for clarification of the Bidding documents

which it receives no later than seven (7) days prior to the deadline for the submission of Bids prescribed in the Bid Data Sheet. Written copies of the Procuring Agency's response (including an explanation of the query but without identifying) will be sent to all prospective Bidders that have received the Bidding documents.

- ii) A prospective Bidder requiring any clarification of the Bidding Documents may notify the Procuring Agency in writing or in electronic form that provides record of the content of communication at the Procuring Agency's address indicated in the **BDS**.
- iii) The Procuring Agency will within three (3) working days after receiving the request for clarification, respond in writing or in electronic form to any request for clarification provided that such request is received not later than seven (7) days prior to the deadline for the submission of Bids. As prescribed in **ITB 2.2.2 (i), above**. However, this clause shall not apply in case of alternate methods of Procurement.
- iv) Copies of the Procuring Agency's response will be uploaded on the website of procuring agency on given date and forwarded to identified Prospective Bidders through an expeditious identified source of communication, e.g.: e-mail etc., including a description of the inquiry, but without identifying its source.
- v) Should the Procuring Agency deem it necessary to amend the Bidding Documents as a result of a clarification, it shall do so following the procedure under **ITB 2.2.3**.
- vi) If indicated **in the BDS**, the Bidder's designated representative is invited at the Bidder's cost to attend a pre-Bid meeting at the place, date and time mentioned **in the BDS**. During this pre-Bid meeting, prospective Bidders may request clarification of the schedule of requirement, the Evaluation Criteria or any other aspects of the Bidding Documents.
- vii) Minutes of the pre-Bid meeting, if applicable, including the text of the questions asked by Bidders, including those during the meeting (without identifying the source) and the responses given, together with any responses prepared after the meeting will be transmitted promptly to all prospective Bidders who have obtained the Bidding

Documents and by uploading same on the website of the procuring agency. Any modification to the Bidding Documents that may become necessary as a result of the pre-Bid meeting shall be made by the Procuring Agency exclusively through the use of an Addendum pursuant to ITB 2.2.3. Non-attendance at the pre-Bid meeting will not be a cause for disqualification of a Bidder.

2.2.3. Amendment of Bidding Documents

- i) At any time prior to the deadline for submission of Bids, but not later than three (3) days before the closing date of the submission of Bid, the Procuring Agency, for any reason, whether at its own initiative or in response to a clarification requested by a prospective Bidder, may modify the Bidding documents by amendment. Any such change/amendment in the Bidding documents shall be provided in a timely manner, preferably through electronic means also, not later than three (3) days, and on equal opportunity basis as per Rule-25(3) OR Rule 25(4) of PPR-14 as the case may be.
- ii) In order to allow prospective Bidders reasonable time in which to take an addendum into account in preparing their Bids, the Procuring Agency, at its discretion, may extend the deadline for the submission of Bids, as per rule 29 of PPR-14, in the manner similar to the original advertisements, so as to avoid any inconvenience and to doubly ensure level playing field for all prospective bidders.

2.3. Preparation of Bids

2.3.1. Language of Bid

- i) The Bid prepared by the Bidder, as well as all correspondence and documents relating to the Bid exchanged by the Bidder and the Procuring Agency shall be written in the language specified in the Bid Data Sheet. Supporting documents and printed literature furnished by the Bidder may be in same language.

2.3.2. Bid Form

- i) The Bidder shall complete the Bid Form and the appropriate Price Schedule (Financial Bid) furnished in the Bidding documents, indicating the goods to be supplied, a brief description of the goods, their country of origin, quantity, and prices.

2.3.3. Bid Prices

- i) The Bidder shall indicate on form 8.10 the unit prices (where applicable) and total Bid price of the goods it proposes to supply under the contract.

- ii) Prices indicated on the Price Schedule shall be item wise.
- iii) The Bidder's separation of price components in accordance with ITB Clause 2.3.3(ii) above will be solely for the purpose of facilitating the comparison of Bids by the Procuring Agency and will not in any way limit the Procuring Agency's right to contract on any of the terms offered.
- iv) Prices quoted by the Bidder shall be fixed during the Bidder's performance of the contract and not subject to variation on any account, unless otherwise specified in the Bid Data Sheet. A Bid submitted with an **adjustable price quotation** will be treated as non-responsive and may be rejected.

2.3.4. Bid Currencies

- i) Prices shall be quoted in **Pak Rupees** for local/DDP items unless otherwise specified in the Bid Data Sheet.

2.3.5. Documents Establishing Bidder's Eligibility and Qualification

- i) Pursuant to ITB Clause 2.1.3, the Bidder shall furnish, as part of its Bid, documents establishing the Bidder's eligibility to Bid and its qualifications to perform the contract if its Bid is accepted.
- ii) The documentary evidence of the Bidder's eligibility to Bid shall establish to the Procuring Agency's satisfaction that the Bidder, at the time of submission of its Bid, is eligible as defined under ITB Clause 2.1.3.
- iii) The documentary evidence, of the Bidder's qualifications to perform the contract if its Bid is accepted, shall establish to the Procuring Agency's satisfaction:
 - (a) that, in the case of a Bidder offering to supply goods under the contract which the Bidder did not manufacture or otherwise produce, the Bidder has been duly authorized by the goods' Manufacturer [*Manufacturer's Authorization form No. 8.3*] or producer to supply the same in Pakistan;
 - (b) that the Bidder has the financial, technical, and production capability necessary to perform the contract;
 - (c) that, in the case of a Bidder not doing business within Pakistan, the Bidder is or will be (if awarded the contract) represented

by an Agent in that country equipped, and able to carry out the Supplier's maintenance, repair, and spare parts-stocking obligations prescribed in the Conditions of Contract and/or Technical Specifications; and

(d) that the Bidder meets the qualification criteria listed in the Bid Data Sheet.

**2.3.6. Documents
Establishing Goods'
Eligibility and
Conformity to
Bidding Documents**

- i) Pursuant to ITB Clause 2.1.4, the Bidder shall furnish, as part of its Bid, documents establishing the eligibility and conformity to the Bidding documents of all goods and related services which the Bidder proposes to supply under the contract.
- ii) The documentary evidence of the eligibility of the goods and services shall consist of a statement in the Price Schedule/Financial Bid Form of the country of origin of the goods and services offered which shall be confirmed by a **Certificate of Origin** issued at the time of shipment.
- iii) The documentary evidence of conformity of the goods and services to the Bidding documents may be in the form of literature, drawings, data and shall consist of:
 - (a) a detailed description of the essential technical and performance characteristics of the goods;
 - (b) a list giving full particulars, including available sources and current prices of spare parts, special tools, etc., necessary for the proper and continuing functioning of the goods for a period to be specified in the Bid Data Sheet, following commencement of the use of the goods by the Procuring Agency; and
 - (c) an item-by-item commentary on the Procuring Agency's Technical Specifications demonstrating **responsiveness** of the goods and services to those specifications, or a statement of deviations and exceptions to the provisions of the Technical Specifications.
- iv) For purposes of the commentary to be furnished, the Bidder shall note that standards for workmanship, material, and equipment, as well as references to brand names or catalogue numbers designated by the Procuring Agency in its Technical Specifications,

are intended to be descriptive only and not restrictive.

- v) Where a sample(s) is required by a procuring agency, the sample shall be:
 - (a) submitted as part of the bid, in the quantities, dimensions and other details requested in the **BDS**;
 - (b) carriage paid;
 - (c) received on, or before, the closing time and date for the submission of bids; and
 - (d) Evaluated to determine compliance with all characteristics listed in the **BDS**.

{However, the procuring agency may also opt to ask for samples after submission of technical bids (where require)}
- vi) The Procuring Agency may retain the sample(s) of the successful Bidder till the successful delivery of the goods. A Procuring Agency may reject the Bid if the sample(s)-
 - (a) do(es) not conform to all characteristics prescribed in the bidding documents; and
 - (b) is/are not submitted within the specified time clearly mentioned in the Bid Data Sheet.
- vii) Where it is not possible to avoid using a propriety article as a sample, a Bidder shall make it clear that the propriety article is displayed only as an example of the type or quality of the goods being Bided for, and that competition shall not thereby be limited to the extent of that article only.
- viii) Samples made up from materials supplied by a Procuring Agency shall not be returned to a Bidder nor shall a Procuring Agency be liable for the cost of making them.
- ix) All samples produced from materials belonging to an unsuccessful Bidder may be kept by the Procuring Agency till thirty (30) days from the date of award of contract or exhaust of all the grievance forums (including those pending at Authority's Level or in some Court of Law).
- x) **Pursuant to the requirements as indicated in ITB 2.3.6, the Bidder shall furnish, as part of its Bid, all those documents establishing**

the eligibility in conformity to the terms and conditions specified in the Bidding Documents for all goods and related services which the Bidder proposes to deliver.

- x) The Bidder shall also furnish a list giving full particulars, including available sources and current prices of goods, spare parts, special tools, etc., necessary for the proper and continuing functioning of the Goods during the period **specified in the BDS** following commencement of the use of the goods by the Procuring Agency.
- xii) The required documents and other accompanying documents must be in English. In case any other language than English is used the pertinent translation attested by the embassy in country of manufacturer into English shall be attached to the original version.

2.3.7. Bid Security

- i) The Bidder shall furnish, as part of its Bid, a Bid security in the amount specified in the Bid Data Sheet.
- ii) The Bid security is required to protect the Procuring Agency against the risk of Bidder's conduct which would warrant the security's forfeiture Pursuant to ITB Clause 2.3.8. (vii).
- iii) The Bid security shall be in Pakistan Rupees and shall be in one of the following forms:
 - (a) Bank Guarantee, Bank call-deposit (CDR), Demand Draft (DD), Pay Order (PO) or Banker's cheque valid for Sixty (60) Days, beyond the validity of Bid.
- iv) Any Bid not secured in accordance with ITB Clauses 2.3.8 (i) and (ii) may be rejected by the Procuring Agency as non-responsive.
- v) Unsuccessful Bidders' Bid security will be discharged or returned as promptly as possible but not later than Thirty (30) days after the expiration of the period of Bid validity prescribed by the Procuring Agency pursuant to ITB Clause 2.3.8 (ii) or along with unopened financial proposal as per rule 38(2)(a)(vii) of PPR-14, which shall take precedence, and is as under:

*“38(2)(a)(vii) the financial proposal of the Bids found technically non-responsive shall be retained unopened and shall be returned on the expiry of the grievance period or the decision of the complaint, if any, filed by the non-responsive Bidder, whichever is later:
provided that the Procuring Agency may return the sealed financial*

proposal earlier if the disqualified or non-responsive Bidder, contractor or consultant submits an affidavit, through an authorized representative, to the effect that he is satisfied with the proceedings of the Procuring Agency”.

- vi) The successful Bidder’s Bid security will be discharged upon the Bidder signing the contract, pursuant to ITB Clause 2.6.1, and furnishing the Performance Guarantee, pursuant to ITB Clause 2.6.2.
- vii) The Bid security may be forfeited:
 - a. If a Bidder withdraws its Bid during the period of Bid validity specified by the Bidder on the Bid Form; or
 - b. In the case of a successful Bidder, if the Bidder:
 - i. Fails to sign the contract in accordance with ITB Clause 2.6.3; or
 - ii. Fails to furnish Performance Guarantee in accordance with ITB Clause 2.6.2; or
 - iii. If the blacklisting proceedings under Section-17A of PPRA Act, 2009 read with Rule-21 of PPR-14 are initiated and the bidder is declared blacklisted after due process of law.

2.3.8. Period of Validity of Bids

- i) Bids shall remain valid for the period specified in the Bid Data Sheet after the date of Bid opening prescribed by the Procuring Agency. A Bid valid for a shorter period may be rejected by the Procuring Agency as non-responsive.
- ii) In exceptional circumstances, the Procuring Agency may solicit the Bidder’s consent to an extension of the period of validity (as per rule-28 of PPR-14). The request and the responses thereto shall be made in writing (or by email). The Bid security provided under ITB Clause 2.3.8 shall also be suitably extended. A Bidder may refuse the request without forfeiting its Bid security. A Bidder accepting the request will not be required nor permitted to modify its Bid.

2.3.9. Format and Signing of Bid

- i) The Bidder shall prepare an original and the number of copies of the Bid indicated in the Bid Data Sheet, clearly marking each “ORIGINAL BID” and “COPY OF BID,” as appropriate. In the event

- of any discrepancy between them, the original shall prevail.
- ii) The Bidder shall authorize a person/ persons for signing, submission and further correspondence with Procuring Agency on behalf of bidder. Authority letter must be part of bid. However, in case of any issue bidder shall be responsible for all consequences.
 - iii) The original and the copy or copies of the Bid shall be typed or written in indelible ink and shall be signed by the Bidder or a person duly authorized to bind the Bidder to the contract. All pages of the Bid, shall be signed and stamped by the authorized person.
 - iv) Any interlineation, erasures, or overwriting shall be valid only if they are initialed by the authorized person for signing the Bid.
 - v) The original and the copy or copies of the Bid shall be typed or written in indelible ink and shall be signed by the Bidder or a person duly authorized to sign on behalf of the Bidder. This authorization shall consist of a written confirmation as specified in the **BDS** and shall be attached to the Bid. The name and position held by each person signing the authorization must be typed or printed below the signature. All pages of the Bid, shall be signed and stamped by the authorized person.
 - vi) Any interlineations, erasures, or overwriting shall be valid only if they are signed by the person or persons signing the Bidder.
 - vii) The Bidder shall furnish information as described in the Form of Bid on commissions or gratuities, if any, paid or to be paid to agents relating to this Bid and to contract execution if the Bidder is awarded the contract.

2.4. Submission of Bids

2.4.1 Sealing and Marking of Bids

- i) As per Rule 24, the Bidder shall seal the original and each copy of the Bid in separate envelopes, duly marking the envelopes as "ORIGINAL" and "COPY." The envelopes shall then be sealed in an outer envelope.
- ii) The inner and outer envelopes shall:
 - a. be addressed to the Procuring Agency at the address given in

- the Bid Data Sheet; and
- b. bear the title of procurement Activity indicated in the Bid Data Sheet, the Invitation to Bids (ITB) title and number indicated in the Bid Data Sheet, and a statement: “DO NOT OPEN BEFORE..... (time and date),” *[to be completed with the time and the date specified in the Bid Data Sheet, pursuant to ITB Clause 2.4.2.]*
- iii) The inner envelopes shall also indicate the name and address of the Bidder to enable the Bid to be returned unopened in case it is declared “late”.
 - iv) If the outer envelope is not sealed and marked as required by ITB Clause 2.4.1 (i), the Procuring Agency will assume no responsibility for the Bid’s misplacement or premature opening.
 - v) In case of Single Stage One Envelope Procedure, the Bidder shall seal the original and each copy of the Bid in separate envelopes, duly marking the envelopes as “ORIGINAL” and “COPY.” The envelopes shall then be sealed in an outer envelope securely sealed in such a manner that opening and resealing cannot be achieved undetected.
Note: The envelopes shall be sealed and marked in accordance with the bidding procedure adopted as referred in Rule-38 of PPR-2014, which shall have precedence.
 - vi) The inner and outer envelopes shall:
 - a) Be addressed to the Procuring Agency at the address given in the **BDS**; and
 - b) Bear the title of the subject procurement or Project name, as the case may be as indicated in the **BDS**, the Invitation to Bids (ITB) title and number indicated in the **BDS**, and a statement: “DO NOT OPEN BEFORE,” to be completed with the time and the date specified in the **BDS**, pursuant to **ITB 2.4.2.**
 - vii) In case of Single Stage Two Envelope Procedure, The Bid shall comprise two envelopes submitted simultaneously, one called the Technical Proposal and the other Financial Proposal. Both envelopes to be enclosed together in an outer single envelope called the Bid. Each Bidder shall submit his bid as under:

- a) Bidder shall submit his TECHNICAL PROPOSAL and FINANCIAL PROPOSAL in separate inner envelopes and enclosed in a single outer envelope.
- b) ORIGINAL and each copy of the Bid shall be separately sealed and put in separate envelopes and marked as such.
- c) The envelopes containing the ORIGINAL and copies will be put in one sealed envelope and addressed / identified as given in BDS.

viii) The inner and outer envelopes shall:

- a) be addressed to the Procuring Agency at the address provided in the BDS;
- b) bear the name and identification number of the contract as defined in the BDS; and provide a warning not to open before the time and date for bid opening, as specified in the BDS, pursuant to ITB 2.4.2;
- c) In addition to the identification required in Sub- Clause (b) hereof, the inner envelope shall indicate the name and address of the Bidder to enable the bid to be returned unopened in case it is declared "late" pursuant to ITB.2.4.3.

ix) If all envelopes are not sealed and marked as required by **ITB 2.4.1** or incorrectly marked, the Procuring Agency will assume no responsibility for the misplacement or premature opening of Bid.

2.4.2 Deadline for Submission of Bids

- i) Bids must be received by the Procuring Agency at the address specified under BDS no later than the time and date specified in the Bid Data Sheet. Bids received through courier services shall not be entertained.
- ii) The Procuring Agency may, at its discretion and as per rule 29 of PPR-14, extend this deadline for the submission of Bids by amending the Bidding documents in accordance with ITB Clause 2.2.2 & 2.2.3 in which case all rights and obligations of the Procuring Agency and Bidders previously subject to the deadline will thereafter be subject to the deadline as extended.
- iii) Bids shall be received by the Procuring Agency at the address specified under **BDS** no later than the date and time specified in the **BDS**.

2.4.3. Late Bids

- i) Any Bid received by the Procuring Agency after the deadline for

submission of Bids prescribed by the Procuring Agency pursuant to ITB Clause 2.4.2 will be rejected and returned unopened to the Bidder.

- ii) The Procuring Agency shall not consider for evaluation any Bid that arrives after the deadline for submission of Bids.
- iii) Any Bid received by the Procuring Agency after the deadline for submission of Bids shall be declared late, recorded, rejected and returned unopened to the Bidder.

2.4.4. Modification and Withdrawal of Bids

- i) The Bidder may modify or withdraw its Bid after the Bid's submission, provided that written notice of the modification, including substitution or withdrawal of the Bids, is received by the Procuring Agency prior to the deadline prescribed for submission of Bids.
- ii) The Bidder's modification or withdrawal notice shall be prepared, sealed, marked, and dispatched in accordance with the provisions of Clause (i) A withdrawal notice may also be sent by email, but followed by a signed confirmation copy, postmarked not later than the deadline for submission of Bids.
- iii) No Bid may be modified after the deadline for submission of Bids.
- iv) No Bid may be withdrawn in the interval between the deadline for submission of Bids and the expiration of the period of Bid validity specified by the Bidder on the Bid Form. Withdrawal of a Bid during this interval may result in the Bidder's forfeiture of its Bid security (along with other remedies available under PPR-14), pursuant to the ITB Clause 2.3.8 (vii).
- v) A Bidder may withdraw its Bid after it has been submitted, provided that written notice of the withdrawal of the Bid, is received by the Procuring Agency prior to the deadline for submission of Bids.
- vi) Revised bid may be submitted after the withdrawal of the original bid before the deadline for submission of Bids.

2.5. Opening and Evaluation of Bids

2.5.1. Opening of Bids by the Procuring Agency

- i) The Procuring Agency will open all Bids, in public, in the presence of Bidders' or their representatives who choose to attend, and other parties with a legitimate interest in the Bid proceedings at the place, on the date and at the time, specified in the **BDS**. The Bidders' representatives present shall sign a register/attendance sheet as proof of their attendance.
- ii) First, envelopes marked "WITHDRAWAL" shall be opened and read out and the envelope with the corresponding bid shall not be opened, but returned to the Bidder. No bid withdrawal shall be permitted unless the corresponding Withdrawal Notice contains a valid authorization to request the withdrawal and is read out at bid opening-
- iii) Second, outer envelopes marked "SUBSTITUTION" shall be opened. The inner envelopes containing the Substitution Bid shall be exchanged for the corresponding Original Bid being substituted, which is to be returned to the Bidder unopened. No envelope shall be substituted unless the corresponding Substitution Notice contains a valid authorization to request the substitution and is read out and recorded at bid opening.
- iv) Next, outer envelopes marked "MODIFICATION" shall be opened. No Technical Proposal and/or Financial Proposal shall be modified unless the corresponding Modification Notice contains a valid authorization to request the modification and is read out and recorded at the opening of the Bids. Any Modification shall be read out along with the Original Bid except in case of Single Stage Two Envelope Procedure where only the Technical Proposal, both Original as well as Modification, are to be opened, read out, and recorded at the opening. Financial Proposal, both Original and Modification, will remain unopened till the prescribed financial bid opening date.
- v) Other envelopes holding the Bids shall be opened one at a time, in case of Single Stage One Envelope Procedure, the Bidders names, the Bid prices, the total amount of each Bid, the presence or absence of Bid Security, Bid Securing Declaration and such other details as the Procuring Agency may consider appropriate, will be

announced by the Procurement Evaluation Committee.

- vi) In case of Single Stage Two Envelope Procedure, the Procuring Agency will open the Technical Proposals in public at the address, date and time specified in the **BDS** in the presence of Bidders` designated representatives who choose to attend and other parties with a legitimate interest in the Bid proceedings. The Financial Proposals will remain unopened and will be held in custody of the Procuring Agency until the specified time of their opening.
- vii) The envelopes holding the Technical Proposals shall be opened one at a time, and the following read out and recorded: (a) the name of the Bidder; (b) the presence of a Bid Security, if required; and (c) Any other details as the Procuring Agency may consider appropriate.
- viii) Bidders are advised to send in a representative with the knowledge of the content of the Bid who shall verify the information read out from the submitted documents. Failure to send a representative or to point out any un-read information by the sent Bidder`s representative shall indemnify the Procuring Agency against any claim or failure to read out the correct information contained in the Bidder`s Bid.
- ix) No Bid will be rejected at the time of Bid opening except for late Bids which will be returned unopened to the Bidder, pursuant to **2.4.3 (i)**.
- x) The Procuring Agency shall prepare minutes of the Bid opening. The record of the Bid opening shall include, as a minimum: the name of the Bidder and whether or not there is a withdrawal, substitution or modification, the Bid price if applicable.
- xi) The Bidders` representatives who are present shall be requested to sign on the attendance sheet. The omission of a Bidder`s signature on the record shall not invalidate the contents and affect the record.
- xii) Minutes of the Financial Bid Opening shall be recorded and uploaded by the procuring agency on its website or shared to all bidders through e-mail.

2.5.2. Confidentiality

- i) Information relating to the examination, clarification, evaluation and comparison of Bids and recommendation of contract award shall not be disclosed to Bidders or any other persons not officially concerned with such process until the time of the announcement of the respective evaluation report in accordance with the requirements of rule 37 of PPR-14.
- ii) Any effort by a Bidder to influence the Procuring Agency processing of Bids or award decisions may result in the rejection of its Bid.
- iii) Notwithstanding **ITB Clause 2.2.2** from the time of Bid opening to the time of contract award, if any Bidder wishes to contact the Procuring Agency on any matter related to the Bidding process, it should do so in writing or in electronic forms that provides record of the content of communication.

2.5.3. Clarification of Bids

- i) As per rule 33(2) of PPR-14, to assist in the examination, evaluation and comparison of Bids and post-qualification of the Bidders, the Procuring Agency may, at its discretion, ask any Bidder for a clarification of its Bid including breakdown of prices to determine its reasonability. Any clarification submitted by a Bidder that is not in response to a request by the Procuring Agency shall not be considered.
- ii) The request for clarification and the response shall be in writing or in electronic forms that provide record of the content of communication. In case of Single Stage Two Envelope Procedure, no change in the prices or substance of the Bid shall be sought, offered, or permitted. Whereas in case of Single Stage One Envelope Procedure, only the correction of arithmetic errors discovered by the Procuring Agency in the evaluation of Bids should be sought in accordance with ITB Clause 2.5.6.
- iii) The alteration or modification in The Bid which in any way affect the following parameters will be considered as a change in the substance of a bid:
 - a) Evaluation & qualification criteria;
 - b) Required scope of work or specifications;
 - c) All securities requirements;
 - d) Tax requirements;

- e) Terms and conditions of bidding documents.
 - f) Change in the ranking of the Bidder
- iv) From the time of Bid opening to the time of Contract award if any Bidder wishes to contact the Procuring Agency on any matter related to the Bid it should do so in writing or in electronic forms that provide record of the content of communication.

2.5.4. Preliminary Examination

- i) The Procuring Agency will examine the Bids to determine whether they are complete, whether any computational errors have been made, whether required sureties have been furnished, whether the documents have been properly signed, and whether the Bids are generally in order.
- ii) Arithmetical errors will be rectified on the following basis:-
 - a. If there is a discrepancy between the unit price and the total price that is obtained by multiplying the unit price and quantity, the unit price shall prevail, and the total price shall be corrected. If the Supplier does not accept the correction of the errors, its Bid may be rejected, and its Bid security may be forfeited.
 - b. If there is a discrepancy between words and figures, the amount in words will prevail.
- iii) Prior to the detailed evaluation, the Procuring Agency will determine the responsiveness of each Bid to the Bidding documents, pursuant to ITB Clause 2.5.5. For purposes of these Clauses, a responsive Bid is one which conforms to all the terms and conditions of the Bidding documents without material deviations. Deviations from, or objections or reservations to critical provisions, **such as** those concerning **Bid Security** (ITB Clause 2.3.8), **Applicable Law** (GCC Clause 30), **Taxes and Duties** (GCC Clause 32) & mandatory Registrations/ Renewals will be deemed to be a material deviation. The Procuring Agency's determination of a Bid's responsiveness is to be based on the contents of the Bid itself without recourse to extrinsic evidence.
- iv) If a Bid is not responsive, it will be rejected by the Procuring Agency and may not subsequently be made responsive by the Bidder by correction of the non-conformity.

- v) Prior to the detailed evaluation of Bids, the Procuring Agency will determine whether each Bid:
 - a) Meets the eligibility criteria defined in **ITB 2.1.3** and **ITB 2.1.4**;
 - b) Has been prepared as per the format and contents defined by the Procuring Agency in the Bidding Documents;
 - c) Has been properly signed;
 - d) Is accompanied by the required securities; and
 - e) Is responsive to the requirements of the Bidding Documents.
 The Procuring Agency's determination of a Bid's responsiveness will be based on the contents of the Bid itself.

2.5.5. Examination of Terms and Conditions; Technical Evaluation

- i) The Procuring Agency shall examine the Bid to confirm that all terms and conditions specified in the **GCC** and the **SCC** have been accepted by the Bidder without any material deviation or reservation.
- ii) The Procuring Agency shall evaluate the technical aspects of the Bid submitted to confirm that all requirements specified in **Section III-Technical Specifications, Section VII – Schedule of Requirements & Evaluation Criteria as provided in BDS**, have been met without material deviation or reservation.
- iii) If after the examination of the terms and conditions and the technical evaluation, the Procuring Agency determines that the Bid is not responsive in accordance, it shall reject the Bid.

2.5.6. Correction of Errors

- i) Bids determined to be substantially responsive will be checked for any arithmetic errors. Errors will be corrected as follows: -
 - a) If there is a discrepancy between unit prices and the total price that is obtained by multiplying the unit price and quantity, the unit price shall prevail, and the total price shall be corrected, unless in the opinion of the Procuring Agency there is an obvious misplacement of the decimal point in the unit price, in which the total price as quoted shall govern and the unit price shall be corrected;
 - b) If there is an error in a total corresponding to the addition or subtraction of sub-totals, the sub-totals shall prevail and the total shall be corrected; and
 - c) Where there is a discrepancy between the amounts in figures

and in words, the amount in words will govern.

d) Where there is discrepancy between grand total of price schedule and amount mentioned on the Form of Bid, the amount referred in Price Schedule shall be treated as correct subject to elimination of other errors.

ii) The amount stated in the Bid will, be adjusted by the Procuring Agency in accordance with the above procedure for the correction of errors. The concurrence of the Bidder shall be considered as binding upon the Bidder. If the Bidder does not accept the corrected amount, its Bid will then be rejected, and the Bid Security may be forfeited or the Bid Securing Declaration may be executed in accordance with **ITB 2.3.8**.

2.5.7. Conversion to Single Currency

i) As per rule 32(2) of PPR-14, to facilitate evaluation and comparison, the Procuring Agency will convert all Bid prices expressed in the amounts in various currencies in which the Bid prices as follows:

For the purposes of comparison of bids quoted in different currencies, the price shall be converted into a single currency specified in the bidding documents. The rate of exchange shall be the selling rate, prevailing on the date of opening of (financial) bids specified in the bidding documents, as notified by the National Bank of Pakistan on that day, in case of holiday in National Bank of Pakistan on the day of opening financial bids, then previous working day's ex-change rates will prevail.

2.5.8. Post-Qualification & Evaluation of Bids

i) In the absence of **prequalification**, the Procuring Agency will determine to its satisfaction whether the Bidder is qualified to perform the contract satisfactorily, in accordance with the evaluation criteria listed in BDS & pursuant to ITB Clause 2.1.3.

ii) The determination will take into account the Bidder's financial, technical, and production/ supplying capabilities. It will be based upon an examination of the documentary evidence of the Bidder's qualifications submitted by the Bidder, pursuant to ITB Clause 2.3.6, as well as such other information required for eligibility/qualification expressed in Bid Data Sheet as the Procuring Agency deems necessary and appropriate.

iii) The Procuring Agency will **technically evaluate** and compare the

Bids which have been determined to be responsive, pursuant to ITB Clause 2.5.5, as per Technical Specifications required.

- iv) The **financial evaluation** of a Bid will be on the basis of form of Price Schedules/ Financial Bid Form 8.10 to be decided by the Procuring Agency which must include clear cut instruction regarding item wise or package wise evaluation inclusive of prevailing taxes, duties, fees etc.

2.5.9. Contacting the Procuring Agency

- i) Subject to ITB Clause 2.5.3, no Bidder shall contact the Procuring Agency on any matter relating to its Bid, from the time of the Bid opening to the time the evaluation report is made public i.e. 10 days before the contract is awarded. If the Bidder wishes to bring additional information or has grievance to the notice of the Procuring Agency, it should do so in writing.
- ii) Any effort by a Bidder to influence the Procuring Agency during Bid evaluation, or Bid comparison may result in the rejection of the Bidder's Bid.

2.5.10. Grievance Redressal

- i) As per Rule-67 of PPR-14, Procuring Agency shall constitute a Grievance Redressed Committee (GRC) comprising of odd number of persons with proper powers and authorization to address the complaints. The GRC shall not have any of the members of the Procurement Evaluation Committee. The Committee may preferably have one subject specialist depending upon the nature of the procurement in addition to one person with legal background as per their availability to the Procuring Agency.
- ii) Any Bidder feeling aggrieved can file its written complaint against the eligibility parameters or any other terms and conditions prescribed in the Bidding documents found contrary to provision of Rule 33, and the same shall be addressed by the Procuring Agency well before the proposal submission deadline.
- iii) Any party can file its written complaint against the eligibility parameters or any other terms and conditions prescribed in the bidding documents found contrary to provision of Rule 34 and the same shall be addressed by the Procuring Agency well before the proposal submission deadline.

- iv) Any Bidder feeling aggrieved by any act of the Procuring Agency after the submission of his Bid may lodge a written complaint concerning his grievances not later than ten days after the announcement of the Final evaluation reports. In case of single stage - two envelope bidding procedure any bidder feeling aggrieved from technical evaluation may file a grievance within 5 days of announcement of the technical evaluation report. After completion of the technical evaluation process, the procuring agency shall immediately upload the technical evaluation report on the website of PPRA and Procuring Agency for obtaining/ receiving grievance petitions from the prospective bidders (if any).
- v) In case, the complaint/grievance is filed after the issuance of the final evaluation report, the complainant cannot raise any objection on technical evaluation of the report. Provided that the complainant may raise the objection on any part of the final evaluation report in case where single stage one envelop bidding procedure is adopted.
- vi) The GRC shall investigate and decide upon the complaint within fifteen days of the receipt of the complaint. Mere fact of lodging of a complaint shall not warrant suspension of the procurement process.

2.6. Award of Contract

2.6.1. Notification of Award

- i) Prior to the expiration of the period of Bid validity, the Procuring Agency will notify the successful Bidder in writing by registered letter and by email to be confirmed in writing by registered letter, that its Bid has been accepted.
- ii) The notification of award will constitute the formation of the Contract.
- iii) Upon the successful Bidder's furnishing of the Performance Guarantee pursuant to ITB Clause 2.6.2 (i), the Procuring Agency will promptly notify each unsuccessful Bidder and will discharge its Bid security, pursuant to ITB Clause 2.3.8 (v).

2.6.2. Performance Guarantee

- i) Within fifteen (15) days of the receipt of notification of award from the Procuring Agency, the successful Bidder shall furnish the

Performance Guarantee in accordance with the Conditions of Contract, in the Performance Guarantee Form provided in the Bidding documents, or in another form acceptable to the Procuring Agency.

- ii) Failure of the successful Bidder to comply with the requirement of ITB Clause (i) above or ITB Clause 2.6.3 shall constitute sufficient grounds for the annulment of the award and forfeiture of the Bid security along with other remedies available under PPR-14. After that, the Procuring Agency may decide to award the contract to the next lowest evaluated Bidder, keeping in view the Bid validity time, or call for new Bids keeping in view the concept of value for money as defined under rule-2(ae) read with Principles of Procurement as enunciated in rule-4 of PPR-14.

2.6.3. Signing of Contract/ Issuance of Purchase Order

- i) At the same time as the Procuring Agency notifies the successful Bidder that its Bid has been accepted, the Procuring Agency will send the Bidder the Contract Form provided in the Bidding documents, incorporating all agreements between the parties or will issue the purchase order.
- ii) Under rule-63 of PPR-14, where the Procuring Agency requires formal signing of contract, **within fifteen (15) days of receipt of the Contract Form**, the successful Bidder shall sign and mention date of the contract and return it to the Procuring Agency.
- iii) Where no such formal signing is required by the procuring agency, the procuring agency shall issue purchase order after the receipt of required performance guarantee, as per rule 55 of PPR-14.

2.6.4. Award Criteria

- i) Subject to ITB Clause 2.6.2, under rule-55 of PPR-14, the Procuring Agency will award the contract to the successful Bidder whose Bid has been determined to be responsive and has been determined to be the lowest evaluated Bid, provided that the Bidder has been determined to be qualified to perform the contract satisfactorily.

2.6.5. Procuring Agency's Right to Vary Quantities at Time of Award

- i) The Procuring Agency reserves the right at the time of contract award to increase or decrease the quantity of goods and services originally specified in the Schedule of Requirements without any change in unit price or other terms and conditions, on the analogy of rule-59 (c)(iv) of PPR-14 (not more than 15%).

2.6.6. Procuring Agency's Right to Accept or Reject All Bids

- i) As per rule 35 of PPR-14, the Procuring Agency reserves the right to accept or reject all Bids or proposals (and to annul the Bidding process) at any time prior to the acceptance of any Bid or proposal, without thereby incurring any liability towards the Bidders.
- ii) The Bidders shall be promptly informed about the rejection of the Bids, if any
- iii) The Procuring Agency shall upon request communicate to any Bidder, the grounds for its rejection of all Bids or proposals, but shall not be required to justify those grounds.

2.6.7. Re-Bidding

- i) If the Procuring Agency rejects all the Bids under rule 35, it may proceed with the process of fresh Bidding but before doing that it shall assess the reasons for rejection and may, if necessary, revise specifications, evaluation criteria or any other condition for Bidders.

2.6.8. Corrupt or Fraudulent Practices

- i) The Procuring Agency Bidders, Suppliers, and Contractors observe the highest standard of ethics during the procurement and execution of contracts.

“Corrupt practices” in respect of procurement process, shall be as given in S-2 (d) of PPRA, Act, 2009, which is as follows:

“(d) “corrupt practice” means the offering, giving, receiving, or soliciting of anything of value to influence the action of a public official, bidder or Contractor in the procurement process or in Contract execution to the detriment of the procuring agency; or misrepresentation of facts in order to influence a procurement process or the execution of a Contract, collusive practices among bidders (prior to or after bid submission) designed to establish bid prices at artificial, noncompetitive levels and to deprive the procuring agency of the benefits of free and open competition and any request for, or solicitation of anything of value by any public official in the course of the exercise of his duty; it may include any of the following:

- i. Coercive practice by impairing or harming, or threatening to impair or harm, directly or indirectly, any party or the property of the party*

to influence the actions of a party to achieve a wrongful gain or to cause a wrongful loss to another party;

- ii. Collusive practice by arrangement between two or more parties to the procurement process or Contract execution, designed to achieve with or without the knowledge of the procuring agency to establish prices at artificial, noncompetitive levels for any wrongful gain;*
- iii. Offering, giving, receiving or soliciting, directly or indirectly, of anything of value to influence the acts of another party for wrongful gain;*
- iv. Any act or omission, including a misrepresentation, that knowingly or recklessly misleads, or attempts to mislead, a party to obtain a financial or other benefit or to avoid an obligation;*
- v. Obstructive practice by harming or threatening to harm, directly or indirectly, persons or their property to influence their participation in a procurement process, or affect the execution of a Contract or deliberately destroying, falsifying, altering or concealing of evidence material to the investigation or making false statements before investigators in order to materially impede an investigation into allegations of a corrupt, fraudulent, coercive or collusive practice; or threatening, harassing or intimidating any party to prevent it from disclosing its knowledge of matters relevant to the investigation or from pursuing the investigation, or acts intended to materially impede the exercise of inspection and audit process.”*

ii) Blacklisting & Debarment:

Blacklisted Bidders i.e. firms/companies/sole proprietor/ general order suppliers/ JVs etc. and those found involved in “Corrupt Practices” are not allowed to participate in bidding.

Requirements & Procedure for Blacklisting & Debarment:

As per S-17A of PPRA, Act, 2009:

“17A. Blacklisting.– (1) *A procuring agency may, for a specified period and in the prescribed manner, debar a bidder or Contractor from participating in any public procurement process of the procuring agency, if the bidder or Contractor indulges in corrupt practice or any other prescribed practice.*

(2) *The Managing Director may, in the prescribed manner, debar a bidder or Contractor from participating in any public procurement process of all or some of the procuring agencies*

for a specified period.

(3) *Any person, aggrieved from a decision of a procuring agency, may within prescribed period prefer a representation before the Managing Director.*

(4) *A procuring agency or any other person, aggrieved from a decision of the Managing Director, may within prescribed period prefer a representation before the Chairperson whose decision on such representation shall be final.]*

As per rule 21 of PPR-14:

21. Blacklisting.—(1) *A procuring agency may, for a specified period, debar a bidder or Contractor from participating in any public procurement process of the procuring agency, if the bidder or Contractor has:*

(a) acted in a manner detrimental to the public interest or good practices;

(b) consistently failed to perform his obligation under the Contract;

(c) not performed the Contract up to the mark; or

(d) indulged in any corrupt practice.

(2) *If a procuring agency debars a bidder or Contractor under sub-rule (1), the procuring agency:*

(a) shall forward the decision to the Authority for publication on the website of the Authority; and

(b) may request the Authority to debar the bidder or Contractor for procurement of all procuring agencies.

(3) *The Managing Director may debar a bidder or Contractor of any procuring agency from participating in any public procurement process of all or some of the procuring agencies for such period as the Managing Director may determine.*

(4) *Any person aggrieved by a declaration made under rule 20 or a decision under sub-rule (1) of this rule may, within thirty days from the date of the publication of the information on the website of the Authority, file a representation before the Managing Director and the Managing Director may pass such order on the representation as he may deem fit.*

(5) *Any person or procuring agency aggrieved by an order under sub-rule (3) or (4) may, within thirty days of the order, file a representation before the Chairperson and the Chairperson may pass such order on the*

representation as he may deem appropriate.

(6) The mechanism or process for barring a bidder or Contractor from participating in procurement process of a procuring agency, procuring agencies and a representation under this rule is specified in the Schedule appended to these rules.

As per Schedule appended with PPR-14:

SCHEDULE

see sub-rule (6) of rule 21

BLACKLISTING MECHANISM OR PROCESS

1. *The procuring agency may, on information received from any resource, issue show cause notice to a bidder or Contractor.*
2. *The show cause notice shall contain:*
 - (a) *precise allegation, against the bidder or Contractor;*
 - (b) *the maximum period for which the procuring agency proposes to debar the bidder or Contractor from participating in any public procurement of the procuring agency; and*
 - (c) *the statement, if needed, about the intention of the procuring agency to make a request to the Authority for debarring the bidder or Contractor from participating in public procurements of all the procuring agencies.*
3. *The procuring agency shall give minimum of seven days to the bidder or Contractor for submission of written reply of the show cause notice.*
4. *In case, the bidder or Contractor fails to submit written reply within the requisite time, the procuring agency may issue notice for personal hearing to the bidder or Contractor/ authorize representative of the bidder or Contractor and the procuring agency shall decide the matter on the basis of available record and personal hearing, if availed.*
5. *In case the bidder or Contractor submits written reply of the show cause notice, the procuring agency may decide to file the matter or direct issuance of a notice to the bidder or Contractor for personal hearing.*
6. *The procuring agency shall give minimum of seven days to the bidder or Contractor for appearance before the specified officer of the procuring agency for personal hearing.*
7. *The procuring agency shall decide the matter on the basis of the*

available record and personal hearing of the bidder or Contractor, if available.

8. *The procuring agency shall decide the matter within fifteen days from the date of personal hearing unless the personal hearing is adjourned to a next date and in such an eventuality, the period of personal hearing shall be reckoned from the last date of personal hearing.*
9. *The procuring agency shall communicate to the bidder or Contractor the order of debarring the bidder or Contractor from participating in any public procurement with a statement that the bidder or Contractor may, within thirty days, prefer a representation against the order before the Managing Director of the Authority.*
10. *The procuring agency shall, as soon as possible, communicate the order of blacklisting to the Authority with the request to upload the information on its website.*
11. *If the procuring agency wants the Authority to debar the bidder or Contractor from participating in any public procurement of all procuring agencies, the procuring agency shall specify reasons for such dispensation.*
12. *The Authority shall immediately publish the information and decision of blacklisting on its website.*
13. *In case of request of a procuring agency under para 11 or representation of any aggrieved person under rule 21, the Managing Director shall issue a notice for personal hearing to the parties and call for record of proceedings of blacklisting. The parties may file written statements and documents in support of their contentions.*
14. *In case of representation of any aggrieved person or procuring agency under rule 21, the Chairperson shall issue a notice for personal hearing to the parties and may call for the record of the proceedings. The parties may file written statements and documents in support of their contentions.*
15. *In every order of blacklisting under rule 21, the procuring agency shall record reasons of blacklisting and also reasons for short, long or medium period of blacklisting.*
16. *The Authority shall upload all the decisions under rule 21, available with it, on its website. But the name of a bidder or Contractor shall immediately be removed from the list of blacklisted persons on*

expiry of period of blacklisting or order of the competent authority to that effect, whichever is earlier.

17. *An effort shall be made for electronic communication of all the notices and other documents pursuant to this mechanism or process.”*

iii) Furthermore, Bidders must keep themselves aware of the provision stated in clause 5.4 and clause 24.1 of the General Conditions of Contract.

2.6.9. Quantity and volume of the goods to be considered in mind

[Framework Contract Modality]

- i) While quoting the rate in a framework contract, the Bidder must consider the following facts:
- a. Certain volume and quantity of the goods as prescribed in Bid Data Sheet.
 - b. The Bidder have to maintain the rates of the goods for the whole financial year.
 - c. The Bidder should quote the rate as per Price Schedule/ Financial Bid form. In case of non-observance of prescribed format, Financial Bid may be rejected.

Section-III. Technical Specifications

3.1. Scope of Work

1. Design, Supply, Installation, Testing & Commissioning along with (01) years Operation & Maintenance for the project:

“INSTALLATION OF 50 KW AT PSDF BUILDING LAHORE”

Sr. No.	City	Proposed System Capacity (Kw)	Coordinates
1	Lahore	50	31.527848659934396, 74.35239788465884

2. Bidder must verify and supplement by his own investigations the information about site and local conditions. The bidders are advised to visit and examine the site of Works and its surroundings and obtain for themselves on their own responsibility all information that may be necessary for preparing the bid and entering into a contract for construction of the Works. All cost in this respect shall be at the bidder's own expense. However, Employer will assist the Bidder wherever practicable and possible.
3. The Bidder shall sign and stamp the Integrity Pact provided at Form 8.12 to Bid in the Bidding Document for Government procurement contracts exceeding Rupees ten million. Failure to provide such Integrity Pact shall make the bid non-responsive

Scope of Work for Solarization:

The Scope of Work includes but is not limited to the following:

- The scope of services includes PV modules, Hybrid inverters, on-grid inverters, junction boxes, AC, DC distribution boards and cables, DC/AC earthing, lightning arrestors with complete scope, net metering, communication interface, remote monitoring, security and surveillance, electrical up-gradation where required and any other equipment necessary for safe and efficient operation of the system. The scope of services also includes inter-connection of installed PV system with the national grid, and synchronization with existing generator sets.
- The successful bidder must submit shop drawing with layout out plan and Single Line Drawing (SLD), design calculation for PV mounting structure for approval from the Engineer

before the commencement of the work. As built drawing should be provided by the contractor after the completion of work.

- The successful bidder must install Genset Synchronized Compatible Inverters.
- The civil works for the installation of the complete system is included in the scope of the successful bidder.
- The scope of services includes Operation and Maintenance (O & M) of the Solar Power Generation System for the period of One (01) years as well as training for the designated officials of Welfare wing (S&GAD) and Communication and Works (C & W) Department. The successful bidder must provide a complete electrical tool kit at the site for O&M purposes.
- The successful bidder must install the solar PV modules, PCC 1:2:4 concrete size (as per approved design) to be paved on which the structure for solar PV modules will be screwed where required. The civil work will be undertaken so as to cater to wind speeds of up to 40 m/sec. A Standard Assessing Procedure (SAP) report in this regard shall be furnished.
- The successful bidder must provide insurance cover as mandated.
- Prior to installation, **02%** quantity of Solar PV Panels supplied by the successful bidder will be tested by the Centre for Energy Research and Development (CERAD) at University of Engineering and Technology (UET) Kala Shah Kaku Campus.
- The equipment offered should conform in all respects to high standards of engineering, design and workmanship and be capable of performing in commercial operation.
- The supply includes essential spares necessary for operation, routine maintenance and testing of equipment supplied for the agreed time period.
- Any and all fittings and accessories that may not have been mentioned specifically in the specifications but are necessary for the solar PV plant, should be deemed to be included in the specifications and shall be supplied and furnished by the successful bidder without incurring any extra charges.
- The successful bidder must comply with guidelines provided by the concerned management.
- The successful Bidder shall ensure that all work necessary for the safe and efficient working of the system is in compliance with BS OHSAS standards. He/she must provide a First Aid Kit at Site.
- The Employer/Engineer shall verify equipment, and detailed drawings and ensure that all technical specifications are complied with. It reserves its right to reject any work or material, which in its judgment is not in full accordance therewith. The Employer can further ask the successful bidder to provide samples at any stage for clarification.
- The successful bidder must provide a remote monitoring system along with laptop core i7 latest generation/ desktop (s) for security and surveillance.
- The successful bidder must install a zero export device during the net-metering process. The net-metering process includes all charges/fees, approvals, sanction load up-gradation (if required), bi-directional meter, related equipment and inspection.
- The successful bidder must provide a 4-core AC wire from Meter to Inverter Distribution Box (DB) if required.

- The successful bidder must provide an anti-theft box along with a strong internet device. The said internet device package must be valid with the provision of uninterrupted internet for the entire duration of the O&M period of the project. The successful bidder should also provide LDR light (security light) for the plant.
- The successful bidder must install security cameras with access to LED TVs.
- The successful bidder must ensure that any scrap material on site shall be handed over to the concerned management.

Solar PV system should consist of the following equipment:

The proposed Solar Based Power Generation System should comply with the minimum solar capacity requirement as provided in solar potential column.

- i. The accumulative capacity of efficient grid tie inverters should be **equal or greater the solar PV capacity** and array combination. It shall depend on the contractor whether to offer single or a combination of multiple inverters.
- ii. Mounting Structures
- iii. Cables (AC/DC) and Hardware
- iv. Civil/ Mechanical Works
- v. Miscellaneous Item
 - a. Remote Monitoring and Data Logging
 - b. Synchronization Hardware
 - c. Junction Box and Distribution Boxes
 - d. ATS (Automatic Transfer Switch)
 - e. Earthing kit / Protection devices
 - f. Lightning Arrestors
 - g. PVC Pipes and Accessories
 - h. Tool Kit, etc.
- vi. It is recommended that the bidder must visit the site before the preparation of the technical bid.
- vii. Also see the detailed minimum specifications provided.

Minimum Technical Specifications

Note: The technical specifications of the solar panels and allied equipment must fulfill the standard requirements (PSS & IEC) as per the import policy S.R.O 604(I)/2019, Dated 28th May, 2019. Verifiable Test certifications for the required standards must be [provided with the technical proposals. In case of the discrepancy, the mentioned S. R. O shall prevail.

The following are provided the minimum technical requirements for solar panels and allied equipment. "All products shall be compliant to relevant IEC standards/specifications; however, other equivalent international standards may be used where, IEC relevant standard is not available, as per the project requirement.

i. Solar PV Modules

Sr	Item	Minimum Requirement
i.	Module Make	Tier 1, Brand should be verifiable for the procurement year
ii.	Module Capacity	540 Watts or above (as per design)
iii.	Module Type	Poly crystalline/Mono crystalline
iv.	Cell Quality	A Grade (Verifiable)
v.	Module Efficiency	19% or higher
vi.	Power Tolerance	Must be +3% or more
vii.	Operation Cell Temperature	-40°C to +85° C
viii.	Temperature Coefficient	-0.4%/°C or less
ix.	Bypass Diode	As per design
x.	Busbar	9 or higher
xi.	Certification	IEC 61215, 61730, 61439, 60947-3 as amended to date, PID free
xii.	Frame	Must withstand 5400 PA impulse load
xiii.	Junction Box	IP67 or better
xiv.	Cable	4mm ² (IEC), 100mm or higher (as per design)
xv.	Connectors	MC4 or comparable weatherproof
xvi.	Front cover	3.2mm thick prism type tempered glass or higher
xvii.	Product Warranty and Guarantee	10 years product replacement warranty Power output within 10 years shall not fall below 90% Power output within 25 years shall not fall below 80%

Sr	Item	Minimum Requirement
		10 years full replacement of module. If the major components malfunctioning. PV module performance guarantee 25 years or more. Annual degradation shall remain less than 1% per annum.

(ii) On-Grid Smart Inverter

Sr.	Parameters	Min. Specifications required
i.	Inverter Make	1 GW or above deployment in last two years. Renowned and verifiable brand having successful performance history in similar climatic conditions
ii.	Inverter Type	Grid synchronized Pure Sine wave, also able to synchronize with generators on site.
iii.	Output Voltage Range	230VAC/400 VAC \pm 5% for string/micro inverters. for central inverters select as per design
iv.	IP Rating/ Dust Proofing	Preferred IP 65 (IEC 60529) / outdoor use with natural heat sink. (Dust protected with natural heat sink i.e. no forced cooling)
v.	Standby power consumption	Max 3 Watt.
vi.	Max. efficiency / Euro-eta	\geq 95% or above
vii.	Protections	<ul style="list-style-type: none"> ▪ Short Circuiting ▪ Surge Protection ▪ PV reverse polarity protection ▪ Anti-Islanding Protection ▪ Leakage current protection ▪ High Insulation <p>Input</p> <ul style="list-style-type: none"> ▪ Over voltage (PV) (if built-in) ▪ Harmonics filter. <p>Output</p>

Sr.	Parameters	Min. Specifications required
		<ul style="list-style-type: none"> ▪ Over voltage (AC)
viii.	Operating temperature for ambient	-5°C to 55°C
ix.	Humidity	10 ~ 90%RH
x.	THD	≤ 3%As per IEC 61000-3-2 (As amended to date)
xi.	Communication	With remote monitoring feature. Mobile App. Web server user interface, Cloud connected. Real time system monitoring, alerts, faults, and warning data display. System statistics- System parameters, PV predicted values, Forecasted values, Load data, Energy Data, Net metering Data Control
xii.	Performance guarantee	5 years Replacement Guarantee 10 years equipment life guarantee
xiii.	Warranty	10 years or above transferable warranty from the original inverter manufacturer shall be provided
xiv.	Input Voltage Range	150-950V or above (depend upon the selected design)
xv.	Power Factor	0.9 leading 0.9 lagging Grid code compliant
xvi.	Applicable Standards and Compliances	IEC 62109-1, IEC62109-2, IEC 61683, IEC 62116, IEC 61727, UL:1741/IEEE:1547,60068-2. (As amended to date)

(iii) Hybrid Solar Inverter

Parameters	Min. Specifications required
Inverter Make	500MW or above deployment in last five years. Renowned and verifiable brand having successful history in similar climatic conditions. Pure Hybrid Inverter
Inverter Type	Grid synchronized Pure Sine wave, Hybrid

Parameters	Min. Specifications required
Phase	3 Phase IN /3 Phase OUT
Parameters	Min. Specifications required
	Also able to synchronize with generators on site.
PV INPUT	
Max DC Input Voltage	900 VDC
Minimum MPPT Range	250~850 VDC
Reverse Polarity Protection	Yes
Photo voltaic array isolation control	Yes
AC Grid Connection	Three-Phase
Management	Intelligent Energy Management System
AC INPUT	
Minimum AC Input Voltage Range	180~260 VAC per phase
GRID OUTPUT	
Nominal Output Voltage	230 VAC (P-N)/400 VAC (P-P)
Output Voltage Range	184~265 VAC per phase
Environmental	
Ambient Temperature Range	-5°C~+55°C
Relative Humidity	4....100% condensing
Acoustic noise emission level	<50 dB@ 1m
Safety and EMC standard	IEC/EN 62109,IEC/EN 62109-2, IEC 62477-1, EN 61000-6-3, EN 61000-3-2,EN 61000-3-3, EN61000-3-11, EN61000-3-12
IP Protection	IP 65 or better
Frequency	50Hz +/- 3%
Standby power consumption	Max 3 Watt.
Max. efficiency / Euro-eta	95% or above

Parameters	Min. Specifications required
Protections	Short Circuiting <ul style="list-style-type: none"> ▪ Surge Protection ▪ PV reverse polarity protection ▪ Leakage current protection ▪ High Insulation Input <ul style="list-style-type: none"> ▪ Over voltage (PV) (if built-in) ▪ Harmonics filter as per IEC standards Output ▪ Over voltage (AC)
THD	≤ 3%, As per IEC 61000-3-2(as amended to date)
Genset	Compatible with Auto start/stop feature
Communication	With Remote Monitoring Feature, Mobile App, Web server user interface, Cloud Connected
Warranty	5 Years or above transferrable warranty from the original inverter manufacturer shall be provided or as defined in the RFP.

(iv) Charge Controller

- IEC:62509
- Maximum Power Point Tracking (MPPT) tracing efficiency > 98%
- External/Built-In charge controller with Hybrid Inverter
- Minimum 2 independent MPPTs.
- Warranty- 5 Years transferrable warranty from the original manufacturer.

The following technical data but not limited to shall be provided wherever applicable for, such as inverter, charge controller, batteries

Sr.No.	Characteristic
1.	Manufacturer Name & Country of Manufacturing
2.	Type/Model number/Date of Manufacture
3.	Datasheet
4.	Certifications
5.	Warranties
6.	Installation Guide
7.	Operation Manual

(v) Mounting Structure

Description	Requirement
Following are Tentative outlines, Actual design will be site dependent and may varies	
Roof Structure material	Standard Aluminium Frame. With more than 20 years of proven life
In case of Pole Mounting	The height of the pole shall not be less than (3) meters. Also be used for parking purpose, strong supporting structure, made of stainless steel or hot dip galvanized iron with minimum galvanization of 90 Microns.
Theft Protection	The mounting structure must come with an anti-theft protection to impede demounting of modules.
Material Gauge	SWG 14 or better / as per design. Fasteners, Nut, Bolts, Clamps) must be of stainless steel
Material and Wind loading	<ul style="list-style-type: none"> • Mounting structure to support the module must be made of durable material, resistant to sandstorms, high wind speeds (up to 40 m/s), • Corrosion (passing the salt spray test IEC 61701, among other verification), and UV induced degradation. • The material must be compatible with the module frame material so as to avoid any adverse electrolytic/galvanic effects.
Civil work	<ul style="list-style-type: none"> • Structure should support the existing roof top/ground mounting. The design shall be able to withstand the maximum wind loading requirements of 40m/s. Design shall be supported with proper calculations. • The stability of the supporting structure after installation shall be guaranteed by the bidder. • To avoid the drilling in roofs, use appropriate arrangements for strengthen the structure without damage the roofs. • Pointed dead-loads on rooftop surface must be avoided. • Additional beams can be casted to avoid drilling on roofs • Water drainage must not be considered; separate water channels must be maintained for water drainage. • The supporting structure must be grounded for short-circuit and lightning protection through independent earthing.

(vi) Cabling, Combiner Boxes and Earthing

- All exposed wiring (with the possible exception of the module interconnects) must be covered in conduits/duct. Wiring through roofing, walls and other structures must be protected through the use of bushings. Wiring through roofing must form a waterproof seal (applicable for wiring only).
- For conduit and duct flexible PVC material with suitable size must be use, so that ¼ spaces in a conduit should be empty.
- Field installed wiring must be joined using terminal strips or screw connectors. Soldering or crimping in the field must be avoided if at all possible. Wire nuts are not allowed. The rated current carrying capacity of the joint must not be less the circuit current rating. All connections must be made in junction boxes. Fittings for lights, switches, and polarity sensitive socket outlets may be used as junction boxes where practical.
- All wiring shall be color coded as per IEC standards and labeled at termination point.
- No conduit or fitting shall be attached directly to thatch or any other non-supportive surface. Especially avoid installing the conduit direct over the roof; there must be distance not less than 2 inches between the roof surface and conduit/duct.
- Cables must be joined by the use of unction boxes, screw-connectors, and block connectors, MC 4 or equaling connectors must be used for PV joints.
- All wires must be terminated with proper end sleeves and wire thimbles with different colors for positive and negative polarity.
- Size, voltage grade and manufacturer name should be printed on every cable.
- Cable voltage drop specifications are as followed that must be verified through software simulation/ Calculations.
- Earthing as per NEPRA net metering rules for all sites.

1. PV to inverter:	Voltage drop less than 2% tin coated (Stranded and flexible), 99.9 % pure copper fire resistive insulation (Stranded) All open/ Exposed cables must be UV resistive.
2. Grid / LV DB to Inverter	Voltage drop less than 2%, 99.9 % pure copper fire resistive insulation (Stranded)

(vii) Solar PV Combiner Boxes

Parameters	Description
PV Input	As per design
PV Max. Input Voltage	1000VDC (IEC) or Higher

Parameters	Description
Number of PV array inputs	As per design
Protections	Lightening Protection
	DC over voltage protection
	Short circuit Protection
	Fuse/Breaker Protection.
	AC & DC disconnect
Protection Class	IP 66 or better
Relative humidity	10~90%

(viii) Lightning/air termination rod and Surge Protection devices

Parameters	Min. Specifications Required
Air termination rod material	99 % Copper
Air termination rod length	As per design
Earthing Pit	Less than 2 Ohm (NEC Codes) 99 % Pure copper plate/ rod Size & weight of plate/rod varies from site to site
Air termination rod diameter	As per design
Air termination rod	As per design
Cable for structure	2.5 mm ² or higher, 99.99% pure copper (strip
Cable for interconnecting/ Grounding metal structure	6 mm ² or higher, 99.99% pure copper
Insulated Spacer	As per design
Cable Bracket	As per design
Stand – Fang Fix system	As per design
Recommended method for calculation	Rolling sphere method
Functional Compliance	IEC 62305-3 (EN62305-3) IEC62305-3 (EN 62305-3) or equivalent

(ix) Surge Arrester

Parameters	Min. Specifications required
Applications	Both DC side & AC sides
Discharge current (I max)	min. 20kA (8/20 μ sec.)
Impulse current (I imp)	min. 25kA (10/350 μ sec.)

Response time	≤ 50nsec
Leakage current	≤ 1 mA
Dielectric strength	2000 V AC @ 1 minute
Protection Class	Class 2(Type2) minimum
Discharge voltage	600 V DC (Line to earth) or above (matching the size of
Ingress Protection	Minimum IP20 (placed in IP 65 Box along with other protections)
Short circuit withstand	min. 30kA

ADDITIONAL SPECIFICATIONS AS PER REQUIREMENT OF THE PROJECT

(x) SYSTEM DESIGN

The contractor shall provide all design calculations for the output of the proposed installation before the start the execution of works and completion of first payment Milestone/Deliverable This shall include the following:

- Solar irradiation at the site, detailing the average and monthly the Global Horizontal Irradiance and Direct Normal Irradiance
- Output of each module and total number of modules required
- Module type, performance specifications and warranties
- Mounting arrangements, inclination and orientation of modules, Shop drawings with Layout out plan and SLD, Design calculation for PV mounting structure with stud analysis
- PV system losses
- Electrical system losses
- Temperature co-efficient
- Total Energy Produced
- Performance Ratio
- Total Energy output in kWh to grid per year for power plant with nominal power output verified through software Simulation (PV-syst, HelioScope etc)

(xi) PANEL MOUNTING STRUCTURE:

- a. The panel mounting and structure should be made of galvanized steel of minimum thickness of **4.00 mm Angle/ 2.5mm C Shape Channel**
- b. **A sketch of the mounting frame (As per Actual Site Requirements) showing dimensions of the frame parts should be provided at the time of supply.** c. Fixed Mounting Structure
- d. The main mounting structure will be fixed tilted at an appropriate angle, facing south and will be made of Aluminum material with vertical posts supported by concrete foundations base 3 inches above roof top level.
- e. The mounting structure must be engineered for wind resistance of 40 m/sec.

- f. Module should be fixed with the frame through pure SS bolts. The bolts should be tightened at the required angle.
- g. The Nuts, Bolts & Washers for modules & Mounting structures must be stainless steel material with appropriate gauge.
- h. Shading shall be avoided all over the year (around) from 30 minutes after the sunrise to 30 minutes before sunset (For installation purpose only).
- i. To allow regular cleaning of the solar modules, they should be easily accessible for personnel (For installation purpose only).
- j. Each panel frame structure shall be so fabricated as to be grouted using rawal bolts in cement concrete foundation with steel frame structure at the site
- k. Foundation/mounting structure will be fabricated and installed to achieve full life of 25 years under the local climatic conditions.

(xii) Junction Boxes

SMART Junction boxes with the multi-function of string monitor to detect each string’s voltage, current, and power, plus fault detection and surge protection function. The array junction box has been suitably designed to be integrated into the PV plant. The junction boxes shall have suitable arrangement for the followings.

- Provide arrangement for disconnection for each of the groups. ☐ Provide a test point for each sub-group for quick fault location.
- To provide group array isolation.
- The current carrying ratings of the junction boxes shall be suitable with adequate safety factor to inter connect the Solar PV array.
- To include data collector for Monitoring System.

A DC string meter is integrated into a DC box to provide the capability of collecting the required data/information of string level.

The system diagram of junction box is shown below.

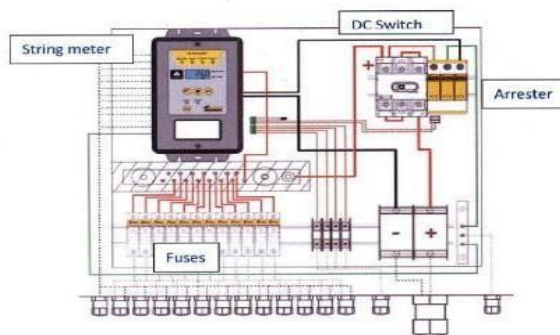

(xiii) CIVIL WORK:

The following civil works should be carried out.

- i. Cutting and clearing of trees/plantation to remove the shadow.
- ii. Drilling exploratory bore holes for earthing and consolidation of the area pertaining to the installation of SPV modules.

- iii. Embedment of concrete structures suitable for mounting PV modules.
- iv. Laying of earthing equipment /structures and connecting to the main ground mat as per the statutory requirements.
- v. Construction work where necessary
- vi. Cutting of cable trenches etc. wherever necessary
- vii. Cutting of the concrete where trenches will be built.
- vi. Underground civil works for cable layout (Sand, Bricks & Warning Tape etc)

(xiv) EXCEPTIONS AND VARIATIONS:

Any exceptions and variations to the specifications must be explicitly stated. The scope and reasons for each listed exception and variation must be fully explained with supporting data.

(xv) WHITE REFLECTIVE / INSULATING PAINT (not applicable)

The Roof Paint should be ultra- white, high reflective, 100% acrylic elastomeric roof sealer designed for fixing leaks in roofs the paint should contain heat reflective pigments and additives that provide an excellent, highly protective barrier which reflects the sun's heat and destructive UV rays leaves a brilliant ultra- white finish, reducing surface heat absorption up 20°F.

The Reflective paint should comply with ASTM D6083, Fiber Reinforced for more protection, strength and durability which allows for contraction and expansion, Resists surface fungal growth.

Note: white reflective is compulsory if contractor is installing Bi-Facial PV modules.

(xvi) OTHER FEATURES:

- a. The PV Module(s) should be warranted for a minimum period of 25 years from the date of supply, inverter with five years and the battery should be warranted for a period of 05 years from the date of installation. The warranty card to be supplied with the system must contain the details of the system. The manufacturers can also provide additional information about the system and conditions of warranty as necessary.
- b. Adequate space should be provided behind the PV module/array for allowing unobstructed airflow for passive cooling.
- c. Cable of appropriate size should be utilized to keep electrical losses to a bare minimum (e.g. length of the wire from module to combiner Box and Combiner Box to Hybrid Inverter should be as minimum as possible).
- d. The control electronics should not be installed directly with the battery. All wiring should be in proper conduit of capping casing. Wire should not be hanging loose.
- e. Instruction and O&M manuals

- f. Two copies of Instruction and Operation and Maintenance Manual in English and local language should be provided with the system.
- g. The manual shall be furnished at the time of dispatch of the equipment and shall include the following aspects:
 - h. Precautions during unpacking
 - i. Instructions for handling at site.
 - j. Erection drawings with written assembly instructions that would enable the Employer to carry out erection with his own personnel if opted by him.
 - k. Detailed instructions and procedures for the installation operation and maintenance. l. Pre-commissioning tests.
 - m. About solar PV system – its components and expected performance.
 - n. Clear instructions about mounting of PV module (s)
 - o. About electronics
 - p. DO's and DONT's
 - q. Principle of Operation of various equipment
 - r. Safety and reliability aspects
 - s. Metering scheme
 - t. About power conditioning units software and controls
 - u. Clear instructions on regular maintenance and troubleshooting of solar power plant.
 - v. Name and address of the person or service center to be contacted in case of failure or complaint.
 - w. Outline dimension drawings showing relevant cross sectional views, earthing details, constructional features. Rated voltages and current etc.

SCOPE OF SERVICES (O&M) :

The Contractor must provide Operation and Maintenance (O & M) services for a period of one (01) yeas including one (01) year defect liability period following which the O & M responsibilities shall be transferred to the Admin Department of PSDF. The capacity building of the respective personnel of PSDF must be undertaken and they shall be provided with comprehensive Operation and Maintenance manuals. A resident engineer along with the necessary support staff needs to be deployed by the Contractor till the expiry of the O&M period.

The responsibility of the Contractor includes but is not limited to ensuring remote monitoring facility at PSDF as specified, periodic preventive maintenance, corrective maintenance as per the O&M form.

The PV Generator is designed for an operation lifetime of at least Twenty (20) years. Its optimal performance is sensitive to best-in-class O&M practices, which will ensure the best performance during the Twenty (20) years period. The bidder is required to describe in detail its definite plans on how to execute the below described requirements for the O&M period. As part of that the bidder shall provide an organizational chart and CVs of the key O&M staff as well as the locations where staff and facilities (e.g., spare parts inventory) will be located.

GENERAL SCOPE OF WORK (O&M)

The contractor has to warrant the performance of the PV Generator within its area of influence, as well as the availability and time consumed for detection of malfunctions and its repair.

This shall include, but not be limited to, the following items:

- Preventive maintenance will be done quarterly according to maintenance programs, such as periodic preventive maintenance of inverters, and PV modules etc., according to manufacturers' requirements.
- Scheduled inspection routines: e.g., PV modules to check for discoloration, first signs of delamination, loose wires in the electronics, corrosion of mounting structures, erosion.
- Maintenance of spare parts inventory (prompt replenishment of used spare parts) including continuous reporting of status and consumption. Corrective maintenance with guaranteed response and reaction times, including all repair and replacement costs which shall not be more than 7 days (backup units must be provided during this period for the supply of uninterrupted power) Technical operation of the PV Generator including presence of O&M personnel close to the Project site as required to fulfil all O&M Contract obligations.

- Regular cleaning of the PV Generator site every 15 days, preventive and corrective maintenance of civil works.
- Relocate, install and commission the complete solar system if and when required by the client during the O&M period.
- Smooth functioning of data communications over Remote Monitoring System.
- Provision of regular service reports about performance, repairs, maintenance, and tests.
- Regular performance of variance analysis of the entire fleet of PV Generators.
- Ensuring that any warranties and insurance policies for the PV Generator are assignable / transferrable to Employer
- Provision of all O&M personnel trained and certified as far as applicable. The staffing concept and selected key employees shall be presented to the Employer for approval.
- Capacity building/raining of the designated personnel for preventive and corrective maintenance.
- Online Complaint Management System should be provided for proper/timely management of the sites.
- 24/7 Helpline contact numbers must be placed near the inverters/DB in metal embossed for emergency/trouble shooting.
- Equipment damaged during this period as a result of improper operations, inadequate maintenance or poor security measures shall be replaced or repaired by the contractor at their expense.
- The contractor shall detail all personnel requirements, security measures, scheduled equipment replacements, maintenance schedules and operational procedures for each year.
- The contractor shall include a guarantee of annual minimum energy output for the PV power plant quoted. Any shortfall in output below this guaranteed minimum shall be paid by the contractor to the client at rates charged by WAPDA per kWh at the time of the shortfall.
- This minimum energy output shall be detailed by the contractor in their proposal by completing the table below:

Size Plant	of	PV	Total energy output in kWh to grid per year	Guaranteed minimum annual output to the grid (kWh)

O&M Operations should be performed as per below format. A log should be maintained and submitted to PSDF and the Client after every three (03) months for the afore-mentioned mentioned site duly signed as and when applicable as per the conditions mentioned above.

Operation and Maintenance Form

Contractor Name:		Designation: _____
CNIC No.:		Contact No.: _____
Date of Visit:		Project Site/Name: _____

Sr. No.	Activities	Checklist	Comments
1.	Cleaning of PV Panels after a month		
2.	Quarterly Preventive Maintenance		
3.	Corrective Maintenance (Prompt response on call)		
4.	PV Module and Inverter Testing		
5.	Breaker/Fuse (AC/DC)		
6.	Earthing and Lightning Arrester Testing		
7.	Miscellaneous connections (Panel Mounting, Cable Mounting, Ducting, etc.)		
8.	Testing of onsite monitoring and online remote monitoring system		
9.	Solar Genset Sync. System		
10.	Capacity Building/Training of personnel of the department.		

<u>Contractor Representative</u>	<u>Department Representative</u>	<u>PSDF Representative</u>
Signature:	Signature:	Signature:
Remarks:	Remarks:	Remarks:

Single Line Diagram for Reference

SINGLE LINE DRAWING (SLD)

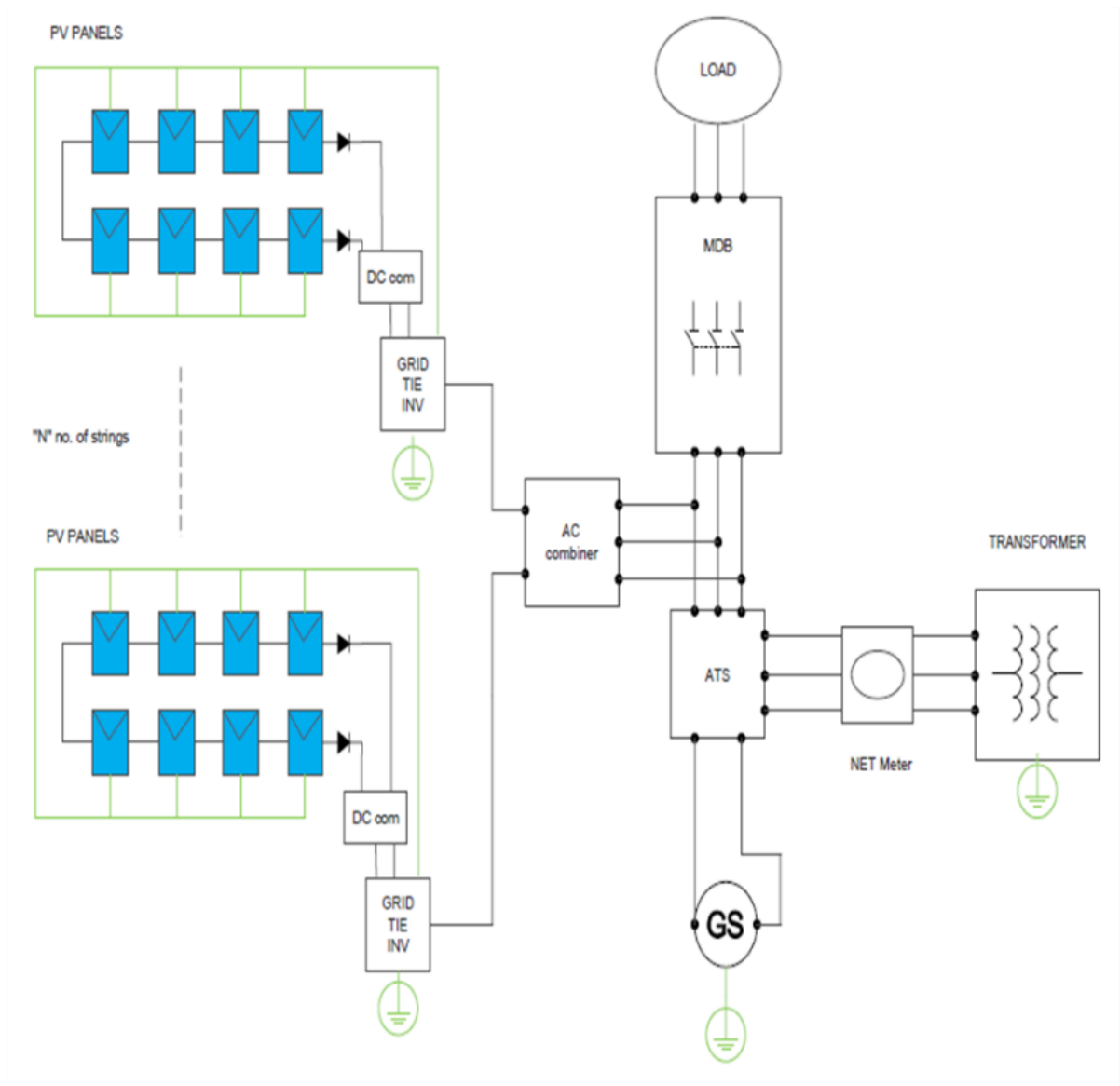

Section-IV: Bid Data Sheet

The following specific data for the goods to be procured shall complement, supplement, or amend the provisions in the Instructions to Bidders (ITB) Section II. Whenever there is a conflict, the provisions herein shall prevail over those in ITB.

A. Introduction		
BDS Clause Number	ITB Number	Amendments of, and Supplements to, Clauses in the Instruction to Bidders
1.	2.1.1	<p>Name of Procuring Agency: Punjab Skills Development Fund.</p> <p>The subject of procurement is: for the design, supply, installation, testing & commissioning and one (01) years operation & maintenance (O&M) of solar system under the project titled “Solarization of Punjab Skills Development Fund (PSDF) Building, Lahore”.</p> <p>Period for Design, Supply, Installation, Testing & Commissioning: Within 3 months of the Effective Date of this Agreement.</p> <p>Commencement date for Design, Supply, Installation, Testing & Commissioning: The successful firm/company shall be bound to provide the required Design, Supply, Installation, Testing & Commissioning after signing the agreement.</p>
2.sss	2.1.2	<p>Financial year for the operations of the Procuring Agency: Financial Year 2024-25</p> <p>Name of Project/ Grant (Development or Non-Development): <i>PSDF (ADP)</i></p> <p>Name of financing institution: PSDF (ADP).</p> <p>Name and identification number of the Contract: Invitation to Bid for Solarization of Punjab Skills Development Fund (PSDF) Building, Lahore, Procurement # 71/SYIG/PSDF/SB</p>
3.	2.1.3 (v)	<p>Maximum number of members in the joint venture, consortium or association shall be:</p> <p>Joint venture of any kind is not allowed to participate in the bid.</p>

		(Please attach a declaration on letterhead that firm/company is not participating as Joint venture.)
4.	2.1.4	Ineligible country(s) is or are: Not Applicable
5.	2.3.6(iii)	Demonstration of authorization by manufacturer: Not Applicable
B. Bidding Documents		
6.	2.2.2	The address for clarification of Bidding Documents is: may be requested by June 26, 2024, before 5:00 PM through message box option of e-tendering portal (https://etender.psdof.org.pk/esop/guest/go/public/opportunity/current) and no response shall be given, if not requested through the message box of e-tendering portal.
7.	2.2.2	Pre-bid meeting will be held on dated June 24, 2024 on 11:00 AM . Those firms/companies who are interested to participate through an online link can request on or before June 23, 2024 by 05:00 PM so that the link could be shared with them. The PSDF's Procurement Team will address and guide the firms/companies regarding the submission of bid on e-tender portal along with the other queries (if any).
8.	2.3.9 & 2.4.1	Single stage two envelopes bidding procedure will be follow, Complete bid containing the Technical (Eligibility & Technical Envelopes) and Financial (Commercial Envelope), with all required information, documentary evidence, and annexures must be submitted on the e-tendering portal before closing date.
9.	2.3.6 (x)	Pursuant to the requirements as indicated in ITB 2.3.6, the firm/company shall furnish, as part of its Bid, all those documents establishing the eligibility in conformity to the terms and conditions specified in the Bidding Documents for all goods which the firm/company proposes to deliver.
C. Bid Price, Currency, Language and Country of Origin		
10.	2.3.1	Language of bid should be English.
11.	2.3.4	The price quoted shall be in PKR. Including all applicable taxes.
12.	2.1.4 (ii)	Country of origin: All eligible countries to do business in Pakistan by the law of Government of Pakistan.

13.	2.3.4	Prices quoted by the firm/company shall be fixed during the firm/company's performance of the contract, duration of this contract shall be one (1) year during which the prices shall be fixed, and contract will be Extendable for another terms.
-----	-------	--

D. Preparation and Submission of Bids

14.	2.1.3	Eligibility / Knock Down Criteria				
		Sr. No	Eligibility Criteria Details	Response/Elaboration/ Proof Required	Attached Supporting Documents/ Proof and mark (Yes/No)	
					YES	NO.
		1	Evidence of the bidding firm / company's registration / incorporation is required.	(Please attach copy of certificate of incorporation / company registration certificate / firm registration certificate.)		
		2	Must be an Active Taxpayer as per "Active Taxpayer List" of FBR.	(Please attach proof to ascertain as active taxpayer in FBR.)		
		3	Must be an Active Taxpayer as per "Active Taxpayer List" of General Sales Tax (GST) / Provincial Sales Tax (PST) where applicable.	(Please attach proof to ascertain that the firm/company is on active list of General Sales Tax (GST) / Provincial Sales Tax (PST).		
4	Pakistan Engineering Council (PEC) in C4 Category or above with field of specialization having code EE11.	(Please attach copy of valid certificate of registration with PEC).				

		5	Certified Installers under AEDB (Certification) Regulations, 2021 Category C-3 or above.	(Please attach evidence).		
		6	Affidavit on stamp paper (duly attested by oath commissioner) as per the form 8.6 of the tender document, declaring that firm/company is not blacklisted or debarred by any organization anywhere in Pakistan.	Please attach copy of Affidavit (as per the form 8.6 of the tender document) on stamp paper, duly attested by oath commissioner , of not less than Rs 100, declaring that the firm/company is not blacklisted, and original affidavit must be delivered to PSDF office as per the mentioned address before the closing date and submission time of the bid.)		
		If the firm/company fails to provide information as per the above-mentioned or does not fulfil the requirement of, "Eligibility Criteria" shall be disqualified and declared ineligible from the bidding process and its technical evaluation shall not be carried out.				
15.	2.2.2	<p>Bid shall be submitted to:</p> <p>Complete bid containing the Technical (Eligibility & Technical Envelopes) and Financial (Commercial Envelope), with all required information, documentary evidence, and annexures must be submitted on the e-tendering portal before closing date.</p> <p>PSDF, Procurement Department on 21 A, H-Block, Dr. Mateen Fatima Road, Gulberg II, Lahore – Pakistan</p>				
16.	2.4.2	<p>The deadline for Bid submission is:</p> <p>July 03, 2024, at 03:00 PM</p>				

17.	2.5.1	Technical proposals shall be publicly opened on the same day i.e., July 03, 2024, at 03:30 PM in the presence of firm/company representatives who wish to attend it at PSDF, Procurement Department on 21 A, H-Block, Dr. Mateen Fatima Road, Gulberg II, Lahore – Pakistan.
18.	2.6.2	Amount of Performance Guarantee is: Successful firm/company will submit a performance guarantee in form of pay-order or bank guarantee or demand draft or Call Deposit Receipt (CDR) of 5% of contract value within fifteen (15) days of the receipt of notification of award/letter of Intent (LOI) from the Procuring Agency which will be returned after completion of contract. For performance guarantee value in PKR purpose the rate of exchange shall be the selling rate, prevailing on the date of opening of (financial) bids specified in the bidding documents, as notified by the National Bank of Pakistan on that day, in case of holiday in National Bank of Pakistan on the day of opening financial bids, then previous working day's ex-change rates will prevail.
19.	2.3.8	Estimated Contract Price is: PKR 7,843,784/- Amount of Bid security is: Bid Security of 0.5% i.e., Rs. 39,219/- (Thirty-Nine Thousand Two Hundred Nineteen Rupees) in the form of a pay-order or demand draft favoring Punjab Skills Development Fund shall reach to PSDF, Procurement Department on 21 A, H-Block, Dr. Mateen Fatima Road, Gulberg II, Lahore – Pakistan before the opening of the bid (Please mention the title of the procurement on envelope). If original bid security is not delivered before the opening of the bid, the firm/company shall be disqualified for further proceeding. The Bid Security should be valid for a period not less than 6 months and a scanned copy must be attached in the financial envelope of the e-tendering portal. Bid Security of disqualified firm/company will be returned after awarding the contract to the successful firm/company on request.
20.	2.3.9	Bid validity period after opening of the Bid is: The bid shall remain valid for the period of 120 days from the date of bid opening.
E. Opening and Evaluation of Bids		
21.	2.5.1	The Bid opening shall take place at: PSDF, 21 A, H-Block, Dr. Mateen Fatima Road, Gulberg II, Lahore – Pakistan.
22.	2.5.7	The currency that shall be used for Bid evaluation and comparison purposes to convert all Bid prices expressed in various currencies is: PKR.

		The rate of exchange shall be the selling rate, prevailing on the date of opening of (financial) bids specified in the bidding documents, as notified by the National Bank of Pakistan on that day, in case of holiday in National Bank of Pakistan on the day of opening financial bids, then previous working day's ex-change rates will prevail.
F. Bid Evaluation Criteria		
23.	2.5.8	The technical proposal of eligible organizations will be evaluated against requirements specified in the evaluation criteria given below. Passing marks for the technical qualification are 65 & above. The Financial bid of only technically qualified firm/company shall be opened.
24.	2.5.8	Financial Evaluation Criteria: Contract shall be awarded based on Least Cost Selection Method. The Financial Proposals of only eligible firm/company with technically qualified will be opened publicly in the presence of firm/company or their representatives who may choose to be present, at the time and place announced prior to the opening. Please provide information regarding Financials Bid Form/Price Schedule 8.10 and commercial envelope of the E-tendering portal.

Technical Evaluation Criteria				
Sr. No.	Descriptions	Total Points	Category Points	Remarks (Attachment of relevant evidence in each case is mandatory. In case of non-compliance, no mark will be awarded)
1	Relevant / Similar Experience in Public Sector	15		Documentary proof (copies of contracts or purchase orders or service orders or completion letter should be furnished. If no valid attachment is provided in Section 1.2.2 (e-tender), then no marks for this section will be awarded.
	More than 10 solar projects of similar nature (50 KW or above) completed in public sector.		15	
	More than 5 or Equal to 10 solar projects of similar nature (50 KW or above) completed in public sector.		10	
2	Relevant / Similar Experience in Private Sector	15		Documentary proof (copies of contracts or purchase orders or service orders or completion letter should be furnished. If no valid attachment is provided in Section 1.3.2 (e-tender), then no marks for this section will be awarded.
	More than 10 solar projects of similar nature (50 KW or above) completed in private sector.		15	
	More than 5 or Equal to 10 solar projects of similar nature (50 KW or above) completed in private sector.		10	
3	Projects in Hand (Public or Private Sector)	10		Documentary proof (copies of contracts or purchase orders or service orders along with starting and completion dates) should be furnished. If no valid attachment is provided in Section 1.4.2 (e-tender), then no marks for this section will be awarded.
	More than 5 solar projects of similar nature (50 KW or above) in hand.		10	
	More than 2 or Equal to 5 solar projects of similar nature (50 KW or above) in hand.		5	
4	Client Portfolio	10		Documentary proof (copies of contracts or purchase orders or service orders or completion letters) should be furnished. If no valid
	Worked with more than 10 local/international clients		10	

	Worked with more than 5 but less than or equal to 10 local/international clients		5	attachment is provided in Section 1.5.2 (e-tender), then no marks for this section will be awarded.
5	Personnel Capabilities (PEC registered engineers)	10		
	More than or Equal to 5 BSc Engineer (PEC Registration) with three (3) years similar experience.		10	Attach the resumes/profile and PEC registration certificates of certified engineers. If no valid attachment is provided in Section 1.6.2 (e-tender), then no marks for this section will be awarded.
	More than 2 Equal to 4 BSc Engineer (PEC Registration) with three (3) years similar experience.		5	
6	Personnel Capabilities (Diploma engineers / technicians)	10		
	More than or Equal to 5 diploma of associates engineers (DAE) / B Tech with three (3) years similar experience.		10	Attach the resumes/profile and DAE / B Tech certificates of certified engineers. If no valid attachment is provided in Section 1.7.2 (e-tender), then no marks for this section will be awarded.
	More than 2 Equal to 4 diploma of associates engineers (DAE) / B Tech with three (3) years similar experience.		5	
7	Equipment Capabilities	10		
	Firm having personalized Tool Kit of Solar with PV Analyzer		5	Documentary proof of equipment capabilities should be furnished on the firm/company's letterhead. If no valid attachment is provided in section 1.8.1 & 1.8.2 (e-tender), then no marks for this section will be awarded.
	Firm having Earth Tester, Insulation Tester		5	
8	Average Turn Over/ Sales/ Revenue of last 3 years	10		Copy of financial audit reports & statements of

	Average revenue / turnover of the firm/company is more than Rs. 30 million.		10	2020-21 / 2021-22/ 2022-23 done by ICAP / SBP / ICMAP registered auditing firm (where applicable as per the law) or tax return of 2020-21 / 2021-22/ 2022-23. If no valid attachment is provided in section 1.9.2 (e-tender), then no marks for this section will be awarded.
	Average revenue / turnover of the firm/company is less than or equal to Rs. 30 million but more than 25 million.		5	
9	3 Years Average Working Capital	10		Copy of financial audit reports & statements of 2020-21 / 2021-22/ 2022-23 done by ICAP / SBP / ICMAP registered auditing firm (where applicable as per the law) and must submit a calculation for the working capital (Working capital = current assets – current liabilities) . If no valid attachment is provided in section 1.10.2 (e-tender), then no marks for this section will be awarded.
	Average working capital of the firm/company is more than Rs. 20 million.		10	
	Average working capital of the firm/company is less than or equal to Rs. 20 million but more than 15 million.		5	
		100		

G. Award of Contract

2.6.5	Percentage for quantity increase or decrease is: <i>[Insert percentage, but not more/ less than 15%]</i> .
2.6.2	<p>The Performance Guarantee shall be: Successful bidder will submit a performance guarantee in form of pay-order or bank guarantee or demand draft or Call Deposit Receipt (CDR) of 5% of contract value within fifteen (15) days of the receipt of notification of award/letter of Intent (LOI) from the Procuring Agency which will be returned after thirty (30) days of completion of contract.</p> <p>For performance guarantee value in PKR purpose the rate of exchange shall be the selling rate, prevailing on the date of opening of (financial) bids specified in the bidding documents, as notified by the National Bank of Pakistan on that day, in case of holiday in National Bank of Pakistan on the day of opening financial bids, then previous working day's ex-change rates will prevail.</p>
2.6.2	The Performance Security (or guarantee) shall be in the form of pay-order or bank guarantee or demand draft or Call Deposit Receipt (CDR)

Section-V: General Conditions of Contract

1. Definitions

1.1 In this Contract, the following terms shall be interpreted as indicated:

- a. "The Contract" means the agreement entered into between the Procuring Agency and the Supplier, as recorded in the Contract Form signed by the parties, including all attachments and appendices thereto and all documents incorporated by reference therein.
- b. "The Contract Price" means the price payable to the Supplier under the Contract for the full and proper performance of its contractual obligations.
- c. "The Goods" means all of the equipment, machinery, and/or other materials which the Supplier is required to supply to the Procuring Agency under the Contract.
- d. "The Services" means those services ancillary and related to the supply of the Goods, such as transportation and insurance, and any other incidental services, such as installation, commissioning, provision of technical assistance, training, maintenance & repair and other such obligations of the Supplier covered under the Contract.
- e. "GCC" means the General Conditions of Contract contained in this section.
- f. "SCC" means the Special Conditions of Contract.
- g. "The Procuring Agency" means the organization purchasing the Goods & Services, as named in SCC.
- h. "The Procuring Agency's country" is the country named in SCC.

- i. "The Supplier" means the Bidder or firm supplying the Goods and Services under this Contract.
- j. "The Project Site," where applicable, means the place or places named in SCC.
- k. "Day" means calendar day.

2. Application

2.1. These General Conditions shall apply to the extent that they are not superseded by provisions of other parts of the Contract.

3. Country of Origin

[where applicable]

3.1. All Goods and Services supplied under the Contract shall have their origin in the countries and territories eligible under the rules, as further elaborated in the SCC.

3.2. For purposes of this Clause, "origin" means the place where the Goods were mined, grown, or produced, or from where the Services are supplied. Goods are produced when, through manufacturing, processing, or substantial and major assembly of components, a commercially recognized new product is obtained that is substantially different in basic characteristics or in purpose or utility from its components.

3.3. The origin of Goods and Services is distinct from the nationality of the Supplier. In any case, the requirements of rules 10 & 26, PPR-14, shall be followed.

4. Standards

4.1. The Goods supplied under this Contract shall conform to the standards mentioned in the Technical Specifications, and, when no applicable standard is mentioned, to the authoritative standards appropriate to the Goods' country of origin. Such standards shall be the latest issued by the concerned institution.

5. Use of Contract Documents and Information; Inspection and Audit by the procuring agency.

5.1. The Supplier shall not, without the Procuring Agency's prior written consent, disclose the Contract, or any provision thereof, or any specification, plan, drawing, pattern, sample, or information furnished by or on behalf of the Procuring Agency in connection therewith, to any person other than a person employed by the Supplier in the performance of the Contract. Disclosure to any such employed person shall be made in confidence and shall extend only so far as may be necessary for purposes of such performance.

5.2. The Supplier shall not, without the Procuring Agency's prior written consent, make use of any document or information enumerated in GCC Clause 5.1 except for purposes of executing the Contract.

5.3. Any document, other than the Contract itself, enumerated in GCC Clause 5.1 shall remain the property of the Procuring Agency and shall be returned (all copies) to the Procuring Agency on completion of the Supplier's performance under the Contract if so required by the Procuring Agency.

5.4. The Supplier shall permit the Procuring Agency to inspect the Supplier's accounts and records relating to the performance of the Supplier and to have them audited by auditors appointed by the donors, if so required by the donors.

6. Patent Rights

6.1. The Supplier shall indemnify the Procuring Agency against all third-party claims of infringement of patent, trademark, or industrial design rights arising from use of the Goods or any part thereof in the Procuring Agency's country.

7. Performance Guarantee

7.1. Within fifteen (15) days [*to be decided by the procuring agency*] of receipt of the notification of Contract award, the successful Bidder shall furnish to the Procuring Agency the Performance Guarantee in the amount specified in SCC/Bid Data Sheet & clause 2.6.2 of ITB.

7.2. The proceeds of the Performance Guarantee shall be payable to the Procuring Agency as compensation for any loss resulting from the Supplier's failure to complete its obligations under the Contract.

7.3. As per Rule-56 of PPR-14, the performance guarantee shall be denominated in the currency of the Contract acceptable to the Procuring Agency and shall be in one of the following forms:

- a) a bank guarantee or an irrevocable letter of credit issued by a reputable bank located in the Procuring Agency's country, in the form provided in the Bidding documents or another form acceptable to the Procuring Agency; or
- b) a Bank Guarantee, Bank call-deposit (CDR), Demand Draft (DD), Pay Order (PO) or Banker's cheque cashier's or certified cheque or CDR.

7.4. The performance guarantee will be discharged by the Procuring Agency and returned to the Supplier not later than thirty (30) days following the date of completion of the Supplier's performance obligations under the Contract, including any warranty obligations, unless specified otherwise in SCC.

8. Inspections and

8.1. The Procuring Agency or its representative shall have the right to inspect and/or

Tests

to test the Goods to confirm their conformity to the Contract specifications at no extra cost to the Procuring Agency. SCC and the Technical Specifications shall specify what inspections and tests the Procuring Agency requires and where they are to be conducted. The Procuring Agency shall notify the Supplier in writing, in a timely manner, of the identity of any representatives nominated for these purposes.

8.2. The inspections and tests may be conducted on the premises of the Supplier or its subcontractor(s), at point of delivery, and/or at the Goods' final destination. If conducted on the premises of the Supplier or its subcontractor(s) (if so allowed by the Procuring Agency), all reasonable facilities and assistance, including access to drawings and production data, shall be furnished to the inspectors at no charge to the Procuring Agency.

8.3. Should any inspected or tested Goods fail to conform to the Specifications, the Procuring Agency may reject the Goods, and the Supplier shall either replace the rejected Goods or make alterations necessary to meet specification requirements free of cost to the Procuring Agency.

8.4. The Procuring Agency's right to inspect, test and, where necessary, reject the Goods after the Goods' arrival in the Procuring Agency's country shall in no way be limited or waived by reason of the Goods having previously been inspected, tested, and passed by the Procuring Agency or its representative prior to the Goods' shipment from the country of origin.

8.5. Nothing in GCC Clause 8 shall in any way release the Supplier from any warranty or other obligations under this Contract.

9. Packing

9.1. The Supplier shall provide such packing of the Goods as is required to prevent their damage or deterioration during transit to their final destination, as indicated in the Contract. The packing shall be sufficient to withstand, without limitation, rough handling during transit and exposure to extreme temperatures, salt and precipitation during transit, and open storage. Packing case size and weights shall take into consideration, where appropriate, the remoteness of the Goods' final destination and the absence of heavy handling facilities at all points in transit.

9.2. The packing, marking, and documentation within and outside the packages shall comply strictly with such special requirements as shall be expressly provided for in the Contract, including additional requirements, if any, specified in SCC, and in any subsequent instructions ordered by the Procuring Agency.

10.1. Delivery of the Goods shall be made by the Supplier in accordance with the

10. Delivery and Documents

terms specified in the Schedule of Requirements. The details of shipping and/or other documents to be furnished by the Supplier are specified in SCC.

[in case of Framework Modality the Procuring Agency may amend these condition as per its requirements]

10.2. Upon delivery, the Procuring Agency shall give receiving certificate to the supplier with the statement that, "completion certificate along with satisfactory report shall be issued after due inspection as per clause-8 of GCC, which will enable the supplier to put up the bill".

[Further conditions may be incorporated by the Procuring Agency keeping in view the nature of contract, DDP, CIF, C&F, FOR, FOP for example; for a DDP contract the clause may be as follows:].

10.3. For purposes of the Contract, DDP trade term used to describe the obligations of the parties shall have the meanings assigned to them by the current edition of *Incoterms*

10.4. Documents to be submitted by the Supplier are specified in SCC.

11. Insurance

[If required and decided by the Procuring Agency]

11.1. The Goods supplied under the Contract shall be delivered *[form of content to be decided by the Procuring Agency]* duty form paid under which risk is transferred to the buyer after having been delivered, hence *[details coverage to be decided by the Procuring Agency]* is sellers responsibility.

12. Transportation

12.1. The Supplier is required under the Contract to transport the Goods to a specified place of destination within the Procuring Agency's country, including *(details to be decided by Procuring Agency as per requirement)* insurance and storage, as shall be specified in the Contract, and related costs shall be included in the Contract Price.

13. Incidental Services

[If required and decided by the Procuring Agency]

13.1. The Supplier may be required to provide any or all of the following services, including additional services, if any, specified in SCC:

- a. satisfactory performance for specified time/ quantity on-site and/or supervision of on-site assembly and/or start-up of the supplied Goods;
- b. furnishing of tools required for assembly and/or maintenance of the supplied Goods;
- c. Ifurnishing of a detailed operations and maintenance manual for each appropriate unit of the supplied Goods;

- d. performance or supervision or maintenance and/or repair of the supplied Goods, for a period of time agreed by the parties, provided that this service shall not relieve the Supplier of any warranty obligations under this Contract; and
- e. Training of the Procuring Agency's personnel, at the Supplier's plant and/or on-site, in assembly, start-up, operation, maintenance, and/or repair of the supplied Goods.

13.2. Prices charged by the Supplier for incidental services shall be included in the Contract Price for the Goods and shall not exceed:

- (i) the prevailing rates charged for other parties by the Supplier for similar services; and
- (ii) original price of goods.

14. Spare Parts

[If required and decided by the Procuring Agency]

14.1. As specified in SCC, the Supplier may be required to provide any or all of the following materials, notifications, and information pertaining to spare parts manufactured or distributed by the Supplier:

- a. such spare parts as the Procuring Agency may choose to purchase from the Supplier, provided that this choice shall not relieve the Supplier of any warranty obligations under the Contract; and
- b. in the event of termination of production of the spare parts:
- c. advance notification to the Procuring Agency of the pending termination, in sufficient time to permit the Procuring Agency to procure needed requirements; and
- d. following such termination, furnishing at no cost to the Procuring Agency, the blueprints, drawings, and specifications of the spare parts, if requested.

15. Warranty

15.1. The Supplier warrants that the Goods supplied under the Contract are new, unused, of the most recent or current models selected by the Procuring Agency, and that they incorporate all recent improvements in design and materials unless provided otherwise in the Contract. The Supplier further warrants that all Goods supplied under this Contract shall have no defect, arising from design, materials, or workmanship (except when the design and/or material is required by the Procuring Agency's specifications) or from any act or omission of the Supplier, that may develop

under normal use of the supplied Goods in the conditions prevailing in the country of final destination.

15.2. This warranty shall remain valid **as required in Section – III “Technical Specifications”** after the Goods, or any portion thereof as the case may be, have been delivered to and accepted at the final destination indicated in the Contract, or **as required in Section – III “Technical Specifications”** after the date of shipment from the port or place of loading in the source country, whichever period concludes earlier, unless specified otherwise in SCC.

15.3. The Procuring Agency shall promptly notify the Supplier in writing of any claims arising under this warranty.

15.4. Upon receipt of such notice, the Supplier shall, within the period specified in SCC and with all reasonable speed, repair or replace the defective Goods or parts thereof, without costs to the Procuring Agency.

15.5. If the Supplier, having been notified, fails to rectify the defect(s) within the period specified in SCC, within a reasonable period, the Procuring Agency may proceed to take such remedial action as may be necessary, at the Supplier’s risk and expense and without prejudice to any other rights which the Procuring Agency may have against the Supplier under the Contract/relevant provision of PPR-14 including Blacklisting.

16. Payment

16.1. The method and conditions of payment to be made to the Supplier under this Contract shall be specified in SCC.

16.2. The Supplier’s request(s) for payment shall be made to the Procuring Agency in writing, accompanied by an invoice describing, as appropriate, the Goods delivered and Services performed, and by documents submitted pursuant to GCC Clause 10, and upon fulfillment of other obligations stipulated in the Contract.

16.3. As per rule-62 of PPR-14, payments shall be made promptly by the Procuring Agency, but in no case later than thirty (30) days after submission of an invoice or claim by the Supplier, provided the work is satisfactory.

16.4. The currency of payment is **as mentioned in Section – III “Technical Specifications”**

17. Prices

17.1. Prices charged by the Supplier for Goods delivered and Services performed

under the Contract shall not vary from the prices quoted by the Supplier in its Bid, with the exception of any price adjustments authorized in SCC.

18. Change Orders

18.1. The Procuring Agency may at any time, by a written order given to the Supplier pursuant to GCC Clause 31, make changes within the general scope of the Contract, only if required for the successful completion of the job, in any one or more of the following:

- a. drawings, designs, or specifications, where Goods to be furnished under the Contract are to be specifically manufactured for the Procuring Agency;
- b. the method of shipment or packing;
- c. The place of delivery; and/or
- d. the Services to be provided by the Supplier.

18.2. If any such change causes an increase or decrease in the cost of, or the time required for, the Supplier's performance of any provisions under the Contract, an equitable adjustment shall be made in the Contract Price or delivery schedule, or both, and the Contract shall accordingly be amended. Any claims by the Supplier for adjustment under this clause must be asserted within thirty (30) days from the date of the Supplier's receipt of the Procuring Agency's change order. But, in no case, the overall impact of the change should exceed 15% of the contract cost and no provisions of PPR-14 should be violated.

19. Contract Amendments

19.1. Subject to GCC Clause 18, no variation in or modification of the terms of the Contract shall be made except by the mutual consent through written amendment signed by the parties. No variation in finalized brands/ makes/models shall be allowed except in special conditions where the manufacturer has stopped producing or suspended that model or the latest model of similar series or version has been launched by the manufacturer or non-availability due to international mergers of the manufacturers or similar unavoidable constraints.

20. Assignment

20.1. The Supplier shall not assign the whole of contract to anybody else. However, some parts of contract or its obligations may be assigned to sub-contractors with the prior written approval of the procuring agency.

21. Sub-contracts

21.1. The Supplier shall notify the Procuring Agency in the Bid of all subcontracts to be assigned under this Contract. Such notification, in the original Bid or later, shall not

relieve the Supplier from any liability or obligation under the Contract.

21.2. Subcontracts must comply with the provisions of GCC Clause 20.

22. Delays in the Supplier's Performance

22.1. Delivery of the Goods and performance of Services shall be made by the Supplier in accordance with the time schedule prescribed by the Procuring Agency in the Schedule of Requirements-

22.2. If at any time during performance of the Contract, the Supplier or its subcontractor(s) should encounter conditions impeding timely delivery of the Goods and performance of Services, the Supplier shall promptly notify the Procuring Agency in writing of the fact of the delay, its likely duration and its cause(s). As soon as practicable after receipt of the Supplier's notice, the Procuring Agency shall evaluate the situation and may at its discretion extend the Supplier's time for performance, with or without liquidated damages, in which case the extension shall be ratified by the parties by amendment of Contract.

22.3. Except as provided under GCC Clause 25, a delay by the Supplier in the performance of its delivery obligations shall render the Supplier liable to the imposition of liquidated damages pursuant to GCC Clause 23, unless an extension of time is agreed upon pursuant to GCC Clause 22.2 without the imposition of liquidated damages.

23. Liquidated Damages

23.1. Subject to GCC Clause 25, if the Supplier fails to deliver any or all of the Goods or to perform the Services within the period(s) specified in the Contract, the Procuring Agency shall, without prejudice to its other remedies under the Contract, deduct from the Contract Price, as liquidated damages, a sum equivalent to the percentage specified in SCC of the delivered price of the delayed Goods or unperformed Services for each week or part thereof of delay until actual delivery or performance, up to a maximum deduction of the percentage specified in SCC. Once the maximum is reached, the Procuring Agency may consider termination of the Contract pursuant to GCC Clause 24 along with other remedies available under PPR-14.

24. Termination for Default

24.1. The Procuring Agency, without prejudice to any other remedy for breach of Contract, by written notice of default sent to the Supplier, may terminate this Contract in whole or in part:

- a. if the Supplier fails to deliver any or all of the Goods within the period(s) specified in the Contract, or within any extension thereof granted by the Procuring Agency pursuant to GCC Clause 22;

- b. if the Supplier fails to perform any other obligation(s) under the Contract; or
- c. if the Supplier, in the judgment of the Procuring Agency has engaged in corrupt practices in competing for or in executing the Contract. For the purpose of this clause, corrupt practices will be defined as per Section-2 (d) of The PPRA Act, 2009.

“Corrupt practices” in respect of procurement process, shall be as given in S-2 (d) of PPRA, Act, 2009:

1.2 “corrupt practice” means the offering, giving, receiving, or soliciting of anything of value to influence the action of a public official, bidder or Contractor in the procurement process or in Contract execution to the detriment of the procuring agency; or misrepresentation of facts in order to influence a procurement process or the execution of a Contract, collusive practices among bidders (prior to or after bid submission) designed to establish bid prices at artificial, noncompetitive levels and to deprive the procuring agency of the benefits of free and open competition and any request for, or solicitation of anything of value by any public official in the course of the exercise of his duty; it may include any of the following:

- vi. coercive practice by impairing or harming, or threatening to impair or harm, directly or indirectly, any party or the property of the party to influence the actions of a party to achieve a wrongful gain or to cause a wrongful loss to another party;*
- vii. collusive practice by arrangement between two or more parties to the procurement process or Contract execution, designed to achieve with or without the knowledge of the procuring agency to establish prices at artificial, noncompetitive levels for any wrongful gain;*
- viii. offering, giving, receiving or soliciting, directly or indirectly, of anything of value to influence the acts of another party for wrongful gain;*
- ix. any act or omission, including a misrepresentation, that knowingly or recklessly misleads, or attempts to mislead, a party to obtain a financial or other benefit or to avoid an obligation;*
- x. obstructive practice by harming or threatening to harm, directly or indirectly, persons or their property to influence their participation in a procurement process, or affect the execution of a Contract or deliberately destroying, falsifying, altering or concealing of evidence material to the investigation or making false statements before investigators in order to materially impede an investigation into allegations of a corrupt, fraudulent, coercive or collusive practice; or threatening, harassing or intimidating any party to prevent it*

from disclosing its knowledge of matters relevant to the investigation or from pursuing the investigation, or acts intended to materially impede the exercise of inspection and audit process

24.2. In the event the Procuring Agency terminates the Contract in whole or in part, pursuant to GCC Clause 24.1, the Procuring Agency may procure, upon such terms and in such manner as it deems appropriate, Goods or Services similar to those undelivered, and the Supplier shall be liable to the Procuring Agency for any excess costs for such similar Goods or Services. However, the Supplier shall continue performance of the Contract to the extent not terminated.

25. Force Majeure 25.1. Notwithstanding the provisions of GCC Clauses 22, 23, and 24, the Supplier shall not be liable for forfeiture of its Performance Guarantee, liquidated damages, or termination for default if and to the extent that its delay in performance or other failure to perform its obligations under the Contract is the result of an event of Force Majeure.

25.2. For purposes of this clause, "Force Majeure" means an event beyond the control of the Supplier and not involving the Supplier's fault or negligence and not foreseeable. Such events may include, but are not restricted to, acts of the Procuring Agency in its sovereign capacity, wars or revolutions, fires, floods, epidemics, quarantine restrictions, and freight embargoes. Both, the Procuring Agency and the Supplier, may agree to exclude certain widespread conditions e.g: epidemics, pandemics, quarantine restrictions etc from the purview of "Force Majeure".

25.3. If a Force Majeure situation arises, the Supplier shall promptly notify the Procuring Agency in writing of such condition and the cause thereof. Unless otherwise directed by the Procuring Agency in writing, the Supplier shall continue to perform its obligations under the Contract as far as is reasonably practical, and shall seek all reasonable alternative means for performance not prevented by the Force Majeure event. Any difference of opinion concerning "Force Majeure" may be decided through means given herein below.

26. Termination for Insolvency 26.1. The Procuring Agency may at any time terminate the Contract by giving written notice to the Supplier if the Supplier becomes bankrupt or otherwise insolvent. In this event, termination will be without compensation to the Supplier, provided that such termination will not prejudice or affect any right of action or remedy which has accrued or will accrue thereafter to the Procuring Agency.

27. Termination for Convenience 27.1. The Procuring Agency, by written notice sent to the Supplier, may terminate the Contract, in whole or in part, at any time for its convenience. The notice of termination shall specify that termination is for the Procuring Agency's convenience, the extent to which performance of the Supplier under the Contract is terminated,

and the date upon which such termination becomes effective.

27.2. The Goods that are complete and ready for shipment (if applicable) within thirty (30) days after the Supplier's receipt of notice of termination shall be accepted by the Procuring Agency on the Contract terms and prices. For the remaining Goods, the Procuring Agency may choose:

- (a) to have any portion completed and delivered at the Contract terms and prices; and/or
- (b) to cancel the remainder and pay to the Supplier an agreed amount for partially completed Goods and Services and for materials and parts previously procured by the Supplier.

28. Resolution of Disputes

28.1. After signing the contract or issuance of purchase order, The Procuring Agency and the Supplier shall make every effort to resolve amicably by direct informal negotiation any disagreement or dispute arising between them under or in connection with the Contract.

28.2. If, after thirty (30) days from the commencement of such informal negotiations, the Procuring Agency and the Supplier have been unable to resolve amicably a Contract dispute, either party may require that the dispute be referred for resolution to the formal mechanisms specified in SCC. These mechanisms may include, but are not restricted to, conciliation mediated by a third party, adjudication in an agreed and/or arbitration as per rule 68 of PPR-14 and in accordance with Arbitration Act-1940.

29. Governing Language

29.1. The Contract shall be written in the language specified in SCC. Subject to GCC Clause 30, the version of the Contract written in the specified language shall govern its interpretation. All correspondence and other documents pertaining to the Contract which are exchanged by the parties shall be written in the same language.

30. Applicable Law

30.1. The Contract shall be interpreted in accordance with the laws of Punjab (Pakistan) unless otherwise specified in SCC.

31. Notices

31.1. Any notice given by one party to the other pursuant to this Contract shall be sent to the other party in writing or by any information technology mean for the time being in use and acceptable in ordinary course of business to the other party's address specified in SCC.

31.2. A notice shall be effective when delivered or on the notice's effective date, whichever is later.

32. Taxes and Duties

32.1. Supplier shall be entirely responsible for all taxes, duties, license fees, etc., incurred until delivery of the contracted Goods & Services to the Procuring Agency. In case of imposition of new taxes/duties or concession thereof after the deadlines for the submission of bids the effect thereof shall be borne or availed by the procuring agency as the case may be.

Section-VI. Special Conditions of Contract

Special Conditions of Contract

The following Special Conditions of Contract shall supplement the General Conditions of Contract. Whenever there is a conflict, the provisions herein shall prevail over those in the General Conditions of Contract. The corresponding clause number of the GCC is indicated in parentheses.

1.3 Definitions (GCC Clause 1)

GCC 1.1 (g)—The Procuring Agency is: **Punjab Skills Development Fund**

GCC 1.1 (h)—The Procuring Agency's country is: **Pakistan**

GCC 1.1 (i)—The Supplier is: **Awardee**

1.4 Country of Origin (GCC Clause 3)

[All countries and territories as indicated in Section IV, BDS, of the Bidding documents]

1.5 Performance Guarantee (GCC Clause 7)

GCC 7.1—As per rule 56 of PPR-14, the amount of Performance Guarantee, as a percentage of the Contract Price, shall be: 5% of contract value.

GCC 7.4—the Performance Guarantee shall be retained for to cover the Supplier's warranty obligations or defect liability period in accordance with Clause GCC 15.2

The Contractor shall cause the validity period of the performance security to be extended for such period(s) as the contract performance may be extended.

1.6 Inspections and Tests (GCC Clause 8)

GCC 8.6—Inspection and tests prior to shipment of Goods and at final acceptance are as follows: *[if so required by the Procuring Agency]*

1.7 Packing (GCC Clause 9)

GCC 9.2—*[This SCC shall supplement GCC Clause 9.2, exact details of the requisite packages be provided]*

1.8 Delivery and Documents (GCC Clause 10)

[format of contract is to be decided by the Procuring Agency, however, a model provision for DDP is as follows]

Sample provision (DDP terms)

GCC 10.3—Upon shipment, the Supplier shall notify the Procuring Agency the full details of the shipment, including Contract number, description of Goods, quantity and usual transport document. The Supplier shall mail the following documents to the Procuring Agency:

- (i) copies of the Supplier's invoice showing Goods' description, quantity, unit price, and total amount;
- (ii) original and two copies of the usual transport document (for example, a negotiable bill of lading, a non-negotiable sea waybill, an inland waterway document, an air waybill, a railway consignment note, a road consignment note, or a multimodal transport document) which the buyer may require to take the goods;
- (iii) copies of the packing list identifying contents of each package;
- (iv) insurance certificate;
- (v) Manufacturer's or Supplier's warranty certificate;
- (vi) Where applicable (Pre shipment/ port/ Procuring Agency Delivery site, inspection certificate), issued by the Procuring Agency nominated inspection agency, and the Supplier's factory inspection report (Inspection type depends on the nature of procurement and volume of procurement); and
- (vii) Certificate of origin.

[Other similar documents should be listed, depending upon the Incoterm provisions.]

1.9 Insurance

(GCC Clause 11) [where applicable]

GCC 11.1— The Goods supplied under the Contract shall be delivered duty paid (DDP) under which risk is transferred to the buyer after having been delivered, hence insurance coverage is sellers responsibility. Since the Insurance is sellers responsibility they may arrange appropriate coverage.

8. Incidental Services (GCC Clause 13)

GCC 13.1—Incidental services to be provided are:

[Selected services covered under GCC Clause 13 and/or other should be specified with the desired features. The price quoted in the Bid price or agreed with the selected Supplier shall be included in the Contract Price.]

9. Spare Parts

(GCC Clause 14) [where applicable]

GCC 14.1—Additional spare parts requirements are:

Sample provision

GCC 14.1—Supplier shall carry sufficient inventories to assure ex-stock supply of consumable spares for the Goods. Other spare parts and components shall be supplied as promptly as possible, but in any case within six (6) months of placing the order and opening the letter of credit.

10. Warranty

(GCC Clause 15)

i. Solar Panels: 10 Years

ii. Inverter: 05 Years

iii. All other allied accessories and Equipment: 02 Years

12. Payment (GCC Clause 16)

Sample provision

GCC 16.1—The method and conditions of payment to be made to the Supplier under this Contract shall be as follows:

Payment for Goods supplied: *[to be decided by the Procuring Agency as per rule-62 of PPR-14]*

Payment by Employer to Contractor after completion of following Milestone/Deliverable shall be as per following break up:

Sr. #	Payment Milestone / Deliverables	Percentage
1.	Survey & Design Approval	5%
2.	Site Preparation (Clearance of Roof, Civil work for PV Mounting Structure)	5%
3.	Supply and Installation of PV Mounting/Elevated Structure	10%
4.	Submission of approved Sample Test Reports of PV Modules, Block Test Reports, Wire Test Reports and Conduits Pipe tests.	5%
5.	Supply of PV Modules and Inverter	15%
6.	Installation of Solar Modules at Site	10%
7.	Installation of Inverter along with Genset Controller, AC Cables, DC Cables and Earthing.	20%

9.	Complete commissioning on Site and upon Installation of Site; real time as well as Online Monitoring Access.	15%
10.	Rectification of Punch List duly verified by the Consultant.	5%
11.	Upon installation of Bi-Directional Meter and submission of Net-Metering Application to DISCO as per NEPRA rules and submission of Final Report after successful completion of the Project duly verified by the Consultant.	10 %
Total		100%

Note:

Payment (s) of all Deliverables shall be made after above-mentioned verification from the Consultant / Admin Department of PSDF.

Payment may be made in Pak. Rupees in the following manner: *(to be decided by the Procuring Agency)*

- (i) Running Bill modality.

13. Prices (GCC Clause 17)

Sample provision

GCC 17.1—Prices shall be fixed and shall not be adjusted.

14. Liquidated Damages (GCC Clause 23)

GCC 23.1—Applicable rate:

Maximum deduction:

The Supplier affirms and acknowledges that any delay in the delivery of the Products will result in a penalty applicable to the Supplier. The penalty shall be one (1%) percent per day, not exceeding a total of ten (10%) of the total value of the Agreement. Such penalty shall be deductible from the amount secured as a Performance Guarantee / invoice from the Supplier.

- 1% per day delay upto 10% of contract value.

15. Resolution of Disputes (GCC Clause 28)

GCC 28.2—The dispute resolution mechanism to be applied pursuant to GCC Clause 28.2 shall be as follows:

As per rule-68 of PPR-14, in the case of a dispute between the Procuring Agency and the Supplier, the dispute shall be referred for arbitration in accordance with the Arbitration Act 1940.

16. Governing Language (GCC Clause 29)

GCC 29.1—The Governing Language shall be:

17. Applicable Law (GCC Clause 30)

GCC 30.1-The Contract shall be interpreted in accordance with the laws applicable in the jurisdiction of the province of Punjab (Pakistan):

18. Notices (GCC Clause 31)

GCC 31.1—Procuring Agency’s address for notice purposes:

—Supplier’s address for notice purposes:

Section-VII. Schedule of Requirements

7.1 Schedule of Requirements

Design, Supply, Installation, Testing & Commissioning shall be provided within three (03) months from the effective date of the contract Agreement along with (01) years Operation & Maintenance for solarization of Punjab Skills Development Fund Building, Lahore.

Any delay in delivery of goods as per agreed time frame will be subject to the following penalties:

- a) 1% per day delay upto 10% of contract value.

Section-VIII: Forms

8.1 Financial Bid Form

[To be signed & stamped by the Goods Provider and reproduced on the letter head. To be attached with the Financial Bid, in case of Single Stage Two Envelope Procedure]

Date: _____

To: *[name and address of Procuring Agency]*

Gentlemen and/or Ladies:

Having examined the Bidding documents including Addenda Nos. *[insert numbers]*, the receipt of which is hereby duly acknowledged, we, the undersigned, in conformity with the said Bidding documents for the sum of *[total Bid amount in words and figures]* or such other sums as may be ascertained in accordance with the Schedule of Prices attached herewith and made part of this Bid.

We undertake, if our Bid is accepted, specified in the Schedule of Requirements.

If our Bid is accepted, we will obtain the guarantee of a bank in a sum equivalent to _____ percent of the Contract Price for the due performance of the Contract, in the form prescribed by the Procuring Agency.

We agree to a Bid by this Bid for a period of *[number]* days from the date fixed to Bid opening under Clause 2.3.8 of the Instructions to Bidders, and it shall remain binding upon us and may be accepted at any time before the expiration of that period.

Until a formal Contract is prepared and executed *(if required)*, this Bid, together with your written acceptance thereof and your notification of award, shall constitute a binding Contract between us.

The Composition of our bid consists on separate Technical and financial bids, detail of which is as follows:

Technical bid includes the following:-

- a) All the forms relevant to the technical bid, to be reproduced on the letter head of the bidder as indicated on each individual form.
- b) Copy of bid security form along with copy of financial instruments *[to be decided by the procuring agency i.e. Bank Guarantee / Bank call-deposit (CDR) / Demand Draft (DD) / Pay Order (PO) or Banker's cheque]* valid for sixty (60) Days, beyond the validity of Bid in the manner as prescribed on the bid security form **8.10**.
- c) Any other document required by the procuring agency not inconsistent with PPR-14.

Financial bid includes the following:-

- a) Original Bid form (as per **form 8.1** of Bidding documents) on letter head of the firm, duly signed and stamped.
- b) Price schedule / financial form (as per **form 8.10**) to be reproduced on the letter head of the bidder duly signed and stamped.
- c) Original Bid security form (as per **form 8.11**) along with Original financial instrument *[to be decided by the procuring agency i.e. Bank Guarantee / Bank call-deposit (CDR) / Demand Draft (DD) / Pay Order (PO) or Banker's cheque]* valid for sixty (60) Days, beyond the validity of Bid.
- d) *Any other document required by the procuring agency not inconsistent with PPR-14.*

Commissions or gratuities, if any, paid or to be paid by us to agents relating to this Bid, and to contract execution if we are awarded the contract, are listed below:

Name and address of goods provider	Amount and Currency

(if none, state "none")

We understand that you are not bound to accept the lowest or any Bid you may receive.

Dated this _____ day of _____ 20_____.

[signature]

[in the capacity of]

Duly authorized to sign Bid for and on behalf of _____

8.2 Bidder's JV Members Information Form
(JV is not allowed for this procurement)

{To be reproduced and signed & stamped by the lead partner and all JV members on their letter Pad, to be attached with Technical Bid in addition to the JV agreement}

{The Bidder shall fill in this Form in accordance with the instructions indicated below. The following table shall be filled in for the Bidder and for each member of a Joint Venture}.

Date: *[insert date (as day, month and year) of Bid submission]*

RFB No.: *[insert number of RFB process]*

Alternative No.: *[insert identification No if this is a Bid for an alternative]*

Page _____ of _____ pages

1. Bidder's Name: <i>[insert Bidder's legal name]</i>
2. Bidder's JV Member's name: <i>[insert JV's Member legal name]</i>
3. Bidder's JV Member's country of registration: <i>[insert JV's Member country of registration]</i>
4. Bidder's JV Member's year of registration: <i>[insert JV's Member year of registration]</i>
5. Bidder's JV Member's legal address in country of registration: <i>[insert JV's Member legal address in country of registration]</i>
6. Bidder's JV Member's authorized representative information Name: <i>[insert name of JV's Member authorized representative]</i> Address: <i>[insert address of JV's Member authorized representative]</i> Telephone/Fax numbers: <i>[insert telephone/fax numbers of JV's Member authorized representative]</i> Email Address: <i>[insert email address of JV's Member authorized representative]</i>
7. Attached are copies of original documents of <i>[check the box(es) of the attached original documents]</i> <input type="checkbox"/> Articles of Incorporation (or equivalent documents of constitution or association), and/or registration documents of the legal entity named above, in accordance with ITB 4.4. <input type="checkbox"/> In case of a state-owned enterprise or institution, documents establishing legal and financial autonomy, operation in accordance with commercial law, and that they are not under the supervision of the Purchaser, in accordance with ITB 4.6.
8. Included are the organizational chart, a list of Board of Directors, and the beneficial ownership.

8.3. Manufacturer's Authorization Form

[To be signed and stamped by the Bidder and to be attached with Technical Bid]

[See Clause 2.3.6 (iii) of the Instructions to Bidders.]

To: *[name of the Procuring Agency]*

WHEREAS *[name of the Manufacturer]*, who are established and reputable manufacturers of *[name and/or description of the goods]* having factories at *[address of factory]* do hereby authorize *[name and address of Agent]* to submit a Bid, and subsequently negotiate and sign the Contract with you against for the above goods manufactured by us.

We hereby extend our full guarantee and warranty as per Clause 15 of the General Conditions of Contract for the goods offered for supply by the above firm against this Invitation to Bids.

[Signature for and on behalf of Manufacturer]

Note: This letter of authority should be on the letterhead of the Manufacturer and should be signed by a person competent and having the power of attorney to bind the Manufacturer. It should be included by the Bidder in its Bid.

8.4. Bidder Profile Form

[To be signed & stamped by the Bidder and reproduced on the letter head. To be attached with Technical Bid]

Organization Information			
Sr. #	Required Information	Response	
1	The legal name of the organization		
2	Year of Registration / Establishment of the Organization		
3	National Tax Number		
	General / Punjab Sales Tax Number		
5	What is the legal status of your organization? Tick the relevant box (one box only). (Attach Copy/Copies of Registration Certificate/s)	Public Sector Organization	
		Section 42 Company	
		Public Ltd. Company	
		Private Ltd. Company	
		Private Partnership Firm	
		Sole Proprietor	
	Others (Please specify)		
6	Name and designation of 'Head of Organization'		
7	Mobile:		
	Phone/s:		
	Email:		
	Fax:		
	Address of organization:		
	Website address:		
8	Name and designation of 'Contact Person':		
	Phone/s:		
	Mobile:		
	Email:		
	Fax:		

1.10 Details of Experience (Last _____ Years)

Relevant Experience		
Sr. #	Required Information	Response (Please provide exact information with the organization name, location/s, and duration) Provide data in the sequence given below
1	Name of Organizations with addresses	i.
		ii.
		iii.
		iv.
2	Start and end dates of providing Goods/Services (For example – Jan 2010 to September 2020)	i.
		ii.
		iii.
		iv.
3	Goods/Services provided to Number of companies/firms	i.
		ii.
		iii.
		iv.

8.5. General Information Form

[To be signed & stamped by the Bidder and reproduced on the letter head. To be attached with Technical Bid]

	Particulars			
Company Name				
Abbreviated Name				
National Tax No.			Sales Tax Registration No	
PRA Tax No.				
No. of Employees			Company's Date of	
			Formation	

*Please attach copies of NTN, GST Registration & Professional Tax Certificate

Registered Office Address		State/Province	
City/Town		Postal Code	
Phone		Fax	
Email Address		Website Address	

8.6. Affidavit

[To be printed on not less than PKR 100 Stamp Paper, duly attested by oath commissioner. To be attached with Technical Bid]

Name: _____

(Applicant)

I, the undersigned, do hereby certify that all the statements made in the Bidding document and in the supporting documents are true, correct and valid to the best of my knowledge and belief and may be verified by employer if the Employer, at any time, deems it necessary.

The undersigned hereby authorize and request the bank, person, company or corporation to furnish any additional information requested by the *[name of Procuring Agency]* of the Punjab deemed necessary to verify this statement regarding my (our) competence and general reputation.

The undersigned understands and agrees that further qualifying information may be requested and agrees to furnish any such information at the request of the *[name of Procuring Agency]*. The undersigned further affirms on behalf of the firm that:

- (i) is not in bankruptcy or liquidation proceedings.
- (ii) is not currently declared blacklisted by Government / Semi- Government / Agency or Authority or any employer till date due to the any reasons
- (iii) is not making any misrepresentations or concealing any material fact and detail.
- (iv) has not been convicted of, fraud, corruption, collusion or money laundering.
- (v) is not aware of any conflict of interest or potential conflict of interest arising from prior or existing contracts or relationships which could materially affect its capability to comply with its obligations; and
- (vi) does not fall within any of the circumstances for ineligibility or disqualifications.
- (vii) The documents/photocopies provided with Bid are authentic. In case, any fake/bogus document was found at any stage, the firm / company shall be blacklisted as per Law/ Rules.
- (viii) The firm comply with Section – III “Technical Specifications”, and Section – VII “Schedule of Requirements” of the Bidding Document.

[Name of the Contractor/ Bidder/ Supplier] undertakes to treat all information provided as confidential.

Signed by an authorized Officer of the company

Title of Officer: _____

Name of Company: _____

Date: _____

8.7. Performance Guarantee Form

(Applicable in case of Bank Guarantee only)

[To be signed & stamped by the Bidder and reproduced on the letter head. To be attached with Technical Bid]

To,

[name and address of the Procuring Agency]

WHEREAS (Name of the Contractor/ Supplier)

_____ hereinafter called "the Contractor" has undertaken, in pursuance of "INVITATION TO BID FOR THE "PROVISION OF _____" procurement of the following:

1.11 *[Please insert details]*.

(Here in after called "the Contract").

AND WHEREAS it has been stipulated by you in the Contract that the Contractor shall furnish you with a bank guarantee by a scheduled bank for the sum specified therein as security for compliance with the Contractor's performance obligations in accordance with the Contract;

AND WHEREAS we have agreed to give the Contractor a Guarantee;

THEREFORE WE hereby affirm that we are Guarantor and responsible to you, on behalf of the Contractor, up to a total of _____ (Amount of the guarantee in words and figures), and we undertake to pay you, upon your first written demand declaring the Contractor to be in default under the Contract, and without cavil or argument, any sum or sums as specified by you, within the limits of _____ (Amount of Guarantee) as aforesaid without your needing to prove or to show grounds or reasons for your demand or the sum specified therein.

This guarantee is valid until _____ day of _____, 20__, or _____ [insert number of days] after the rectification of the Defects, whichever is later.

[NAME OF GUARANTOR]

Signature_____

Name_____

Title_____

Address_____

Seal_____

Date_____

8.8. Technical Bid Form

[(i)To be signed & stamped by the Bidder and reproduced on the letter head. To be attached with Technical Bid.

(ii) Item names and quantities must be reproduced from Section – III (Technical Specifications). If any deviations are needed, it must be mentioned/quoted, separately in the Technical Proposal.]

Sr. No	Items Name	Specification	Brand	Unit	Quantity
1	Imported Equipment				
1.1	Solar Panel	560-585 Watts	JA N Type or Equivalent	Watt	50310
1.1	String Inverter	Grid Tie Inverter 50 KTL with Dongle	Huawei or Equivalent	No.	1.00
2	Mechanical And Civil Work				
2.1	Mounting Structure	Roof Top Structure Elevated HDG with civil work		Watt	50310
3	Cables and Conductors				
3.1	DC cable - Red	4 sq.mm, 1C, PVC/PVC, Rated 1000V	Newage/FAST or Equivalent	Meter	350
	DC cable - Black	4 sq.mm, 1C, PVC/PVC, Rated 1000V	Newage/FAST or Equivalent	Meter	350
3.3	AC cable	35 sq.mm, 3.5C, PVC/PVC, Rated 600/1000 V	Newage/FAST or Equivalent	Meter	10
3.4	Grounding Cable (Panels)	Green Color Single Core Flexible 2.5 sq.mm, CU/PVC	Newage/FAST or Equivalent	Meter	30
3.5	Grounding Cable (Structure)	Green Color Single Core Flexible 2.5 sq.mm, CU/PVC	Newage/FAST or Equivalent	Meter	20
	Grounding Cable (Inverters)	Green Color Single Core Flexible 35 sq.mm, CU/PVC	Newage/FAST or Equivalent	Meter	10.00

3.6	Bare Conductor	6/10/25 sq.mm	Newage/FAST or Equivalent	Meter	10.00
3.7	Communication Cable	Beldon Cable RS485		Meter	30
4	Electrical Equipment and Miscellaneous Items				
4.1	LV Panel	Outdoor rated, equipped with 1 x 125 Amp 4 Pole. Contain all standard accessories and bus bar capable to hold 400 Amps current and earthing bus bar accordingly, Floor mounted type, with Key lock. RYB indication. On/off/trip indication.	Local or Equivalent	No.	1.00
4.2	Lightning Arresters			No.	2.00
4.3	PVC Pipe	4" With Accessories		Meter	40.00
4.4	PVC Pipe	2" With Accessories		Meter	30.00
4.5	Cable tray with cover and accessories	Pre galvanized 300x150 MM 14 SWG		Meter	40.00
4.6	MC4 Connector	Male + female		Pairs	10.00
4.7	Consumable Items	Lugs, thimble, shrouds, etc.		Lot	50310
5	Earthing				
5.1	Earthing Pits	As per site requirement		No.	3.00
5.2	Ground Copper Electrode	Copper strip/Rod		No.	3.00
6	Services				
6.1	Installation Works	Project Design & Execution			
		Mounting Structure Installation			

		Solar Panel installation		Watt	50310
		Electrical Wiring and Equipment Installation			
6.2	Transportation Services			Watt	50310
6.3	Lodging ,Traveling, Project Management, Installation Supervision, Commissioning Services.			Watt	50310
6.4	Net-Metering Process for installed system (including all equipment, Load Flow Study (if applicable), Fee, Approvals, Documentation, Bi-Directional Meter, Inspection). Zero Export Device must be installed during the Net-Metering procedure. Note: Total price must include all applicable fees mandatory for Net-Metering			Watt	50310
6.5	Operations and Maintenance "O&M Services (01 Years)			Watt	50310

Solarization

The **Scope of Work** includes but is not limited the following:

- The Scope of Services includes, PV modules, On-Grid inverters (efficiency 98% or above), junction boxes, AC, DC distribution boards and cables, DC & AC Earthing, Lightning Arrestors with complete scope, communication interface, Remote Monitoring, Electrical Up-gradation where required and any other equipment necessary for safe and efficient operation of the system. Client will be responsible for the upgradation of Sanction Load.
- Successful bidder shall submit System drawing with Layout out plan and SLD, Design calculation for PV mounting structure with stud analysis is required for approval from the Engineer in-Charge before start of the work. As built drawing should be provided by the contractor after completion of work.
- The scope of Services also includes interconnection of installed PV System with the national grid, Synchronization with Existing Generator Sets. Genset Controller, ATS must be installed by the successful bidder.
 - Comprehensive insurance, storage & in transit transportation is also the responsibility of successful bidder.
 - The site clearance & civil works required for installation of complete system is in scope of successful bidder.
 - To install the Solar PV modules, minimum size of PCC 1:2:4 concrete of size 14" x 14" x 12" (Inches) would be paved on which structure for solar PV modules will be screwed. Proper civil work will be done so as to cater wind speed of up to 150 km/hr.
 - The scope of Services should also include operation and maintenance of the Solar Power Generation System for the period of **One (01) year** and the contractor also responsible to be guide/trained the maintenance staff. Whereas, the Construction duration of the Solar Power System will be of **03 months**.
 - Prior to installation, **05%** quantity of Solar PV Panels will be tested by the contractor from CERAD.
 - The scope of supply should also include essential spares necessary for operation, routine maintenance and testing of equipment supplied for agreed time period.
 - All the equipment offered should conform in all respects to high standards/approved standards of engineering, design and workmanship and be capable of performing in commercial operation.
 - All the fittings and accessories that might not have been mentioned specifically in the specification but are necessary for equipment's of the plant, should be deemed to be

included in the scope of specification and shall be supplied and furnished by the installer without any extra charges.

- Successful Bidder must obey the guideline given by the Management of the respective department.
- It should be responsibility of the successful Bidder to ensure all the works as per scope of the specification in safe and efficient way, following safety standards.
- The PSDF management is authorized to interpret during installation and authorized to verify equipment, detailed drawings, specification and should have the power to reject any work or materials, which in his judgment are not in full accordance therewith.
- Roof stability Certificate along with Load Bearing Test and Hammer Test from third party must be submitted by the successful bidder.
- 1:2:4 concrete block testing via certified lab/UET Lab should be submitted by the successful bidder. Sample for block must be sealed and jointly signed & stamped by the Client/Consultant and Contractor. The strength of block must achieve 2800 psi (If applicable).
- Genset Synchronized Compatible Inverters should be installed having efficiency of 98% or above.
- Factory Acceptance Test must be provided by the successful bidder. Supply material must be tested by UET Lab. Structure should be Hot-Dip Galvanized.
- 4-core AC wire from Meter to Inverter Distribution Box (DB), if required, must be provided by the successful bidder. All the cables provided by the successful bidder must be of approved standards.
- Internet device package must be valid with provision of uninterrupted internet till the entire duration of the O&M period (12-Months) of the project.
- The procuring agency may ask the successful bidder to provide sample at any stage for the clarification purpose and the successful bidder must provide a complete electrical tool kit at site for O&M purpose including all necessary equipment along with First Aid Kit.
- Complete Net-Metering process of the installed Solar System must be the responsibility of the successful bidder. PSDF will nominate its focal person for the Net-Metering process that assist the Contractor/Successful bidder for completing the process timely. Net-metering application must be in the name of Point of Contact (POC) nominated by PSDF whereas, the process must be the responsibility of bidder.

- Sanction Load upgradation will be the responsibility of Client.
- Warranty Documents (provided by manufacturer/vendor) must be provided by the successful bidder along with As-Built documents at the time of completion of the project.

Solar PV system should consist of following equipment:

- i. The proposed Solar Based Power Generation System should comprise of minimum **KW** as provided in Solar Potential column.
- ii. The accumulative capacity of Efficient Grid Tie Inverters should be **equal or greater the solar PV capacity** and array combination. It shall depend on the contractor whether to offer single or a combination of multiple inverters.
- iii. Mounting structures (roof mounted or elevated)
- iv. Cables (AC/DC) and hardware provided as per approved standards/specifications.
- v. Civil/ Mechanical Works
- vi. Miscellaneous Item
 - a. Remote Monitoring and Data Logging
 - b. Synchronization Hardware.
 - c. Junction box and distribution boxes
 - d. ATS (Automatic Transfer Switch)
 - e. Earthing kit / Protection devices
 - f. Lightning arrestors
 - g. PVC pipes and accessories
 - h. Tool kit, etc.
- vii. It is recommended that the bidder must visit the site before the preparation of technical bid.

Stamp & Signature of Bidder _____

8.9. Contract Form

DATED ___ Month 2024

**AGREEMENT FOR HIRING OF A FIRM / COMPANY / CONTRACTOR FOR THE SOLARIZATION OF
PSDF BUILDING, LAHORE**

BETWEEN

Punjab Skills Development Fund

AND

Insert Firm / Company / Contractor

This Agreement is for provisioning of solarization services ("**Agreement**") and is made at Lahore, Pakistan this ___ day of month 2024 ("**Effective Date**"):

By and Between

PUNJAB SKILLS DEVELOPMENT FUND, a company incorporated under the Companies Act 2017, having its office at 21-A, H Block, Dr. Mateen Fatima Road, Gulberg II, Lahore (hereinafter referred to as "**PSDF**" which expression shall, wherever the context so requires or permits, include its successors and assigns);

And

COMPANY NAME, ADDRESS (hereinafter referred to as the "**Company**" which expression shall, wherever the context so requires or permits, include its successors and assigns).

('PSDF' and the 'Company' shall individually be referred to as a "Party" and collectively as "Parties")

RECITALS

- A. Whereas**, PSDF is a not-for-profit company established by the Government of Punjab to provide quality skills and vocational training opportunities to the underprivileged segment of the population in order to improve their livelihood prospects. In this regard PSDF desires to engage the Company for the purposes of provisioning of solarisation services ("**Services**") as envisaged herein this Agreement and specified under Appendix-A ("**Scope of Services**");.
- B. AND WHEREAS**, Government of Punjab (GoP) through PSDP, initiated a tender process for the procurement of Services;
- C. And Whereas**, the Company is desirous of providing the aforesaid Services and submitted its proposal/bid on _____[add] and the proposal/bid has been deemed successful for awarding of this Agreement;
- D. And Whereas**, the Company has agreed to offer and PSDF has agreed to procure the envisaged Services on the terms and conditions set out herein below;
- E. And Whereas**, the Recitals and appendices attached hereto shall be read and construed as an integral part of this Agreement.

Now Therefore, in consideration of the promises and mutual covenants contained herein and other good and valuable consideration, the adequacy of which is hereby acknowledged, the Parties agree as follows:

1. Scope of Work

- 1.1. The Company agrees to provide the Services in accordance with the specifications as specified under Appendix-A subject to negotiations in accordance with the PPRA Rules 2014.
- 1.2. The Company further agrees to provide all related services which may be required by PSDF at any time during the term of this Agreement.

2. Term & Payment

- 2.1. This Agreement shall come into force on the effective date [add] and its duration shall be One (1) Year (Extendable for another term)
- 2.2. PSDF may extend the duration of this Agreement for another term with the mutual consent of both the Parties, on the same terms and conditions.
- 2.3. Time is of the essence in this Agreement and, whenever a date or time is set forth in this Agreement, the same has entered into and formed a part of the consideration for this Agreement. In case of any sort of delay in the performance by the Company, PSDF shall be entitled to deduct 1% per day up to a maximum of 10% of the monthly invoice value till such delay continues as per the scope of work.
- 2.4. In consideration of the satisfactory provision of Services and related services, PSDF shall pay an amount (inclusive of all applicable taxes & out of pocket expenses) of PKR [_____]. As per Appendix - B ("**Payment Terms**")
- 2.5. All payments made hereunder shall be made subject to applicable tax deductions.

3. Performance Guarantee

- 3.1. The Company shall submit a Performance Guarantee (in the form of pay order or bank guarantee as is acceptable by PSDF) equal to the amount of 5% of the total value of this Agreement within fifteen (15) days of the receipt of notification of award/letter of intent from PSDF. The Company shall ensure that the Performance Guarantee is valid and enforceable for the duration of this Agreement.

3.2. The Performance Guarantee shall be returned after the successful completion of this Agreement.

4. Obligations

- 4.1. In the provision of Services and related services to PSDF, the Company shall, at all times, observe and comply with all the guidelines and policies of PSDF communicated to the Company from time to time.
- 4.2. The Company shall exercise reasonable care and due diligence in the performance of all obligations arising out of or in relation to this Agreement.
- 4.3. The Company shall carry out all activities under this Agreement with the highest standards of quality, professional and ethical competency and integrity.
- 4.4. The Company shall ensure that the Services provided pursuant to the Agreement are up to the standards as communicated by PSDF and PSDF has the right to request changes to the deliverables and Services provided by the Company to ensure that the Services are as per the requirement and expectation of PSDF.
- 4.5. The Company shall ensure that the Services and all related services provided are of the best quality and comply with the specifications communicated by PSDF to the Company and as laid down in Appendix A.
- 4.6. The Company shall retain and maintain all records related to the Agreement during the life of the Agreement and five (05) years after the expiry of this Agreement.
- 4.7. The Company shall provide professional, objective, and impartial services, at all times holding PSDF's interest's paramount.
- 4.8. The Company shall ensure that the professional staff required for performing the Services and fulfilling its obligations under this Agreement is available at all times.
- 4.9. The Company shall comply with the Business Rules, Monitoring Rules and all other rules of PSDF in providing the Services.

5. Warranties and Representations

5.1. Company's warranties and representations

- i. The Company warrants and represents that it has submitted Performance Guarantee of 5% of the total value of this Agreement as stipulated herein and the tender document to PSDF.
- ii. The Company warrants and represents that it has submitted the Bid Security amounting to PKR 392,439/- (Three Hundred Ninety Two Thousand Four Hundred Thirty Nine Rupees) as stipulated in the tender document to PSDF.
- iii. The Company warrants and represents that it has the legal right and capacity to enter into this Agreement and the execution and delivery of this Agreement has

been duly and validly authorized and no proceedings on part of any person are necessary to authorize this Agreement or to consummate the transactions contemplated hereby.

- iv. The Company is legally entitled, validly existing and carrying on its business under the laws of Pakistan and complies with the eligibility criteria set out in the expression of interest and the request for proposal document.
- v. The Company warrants and represents that it has the required professional skills, knowledge, expertise technical and financial resources required for the purposes of providing the Services and related services and carrying out all related activities in relation to this Agreement.
- vi. The Company warrants and represents that it shall comply with any alteration or replacement requests made by PSDF to ensure that the Services and any related services are up to the standards and expectations of PSDF, at no additional cost to PSDF.
- vii. The Company warrants and represents that the Services provided in connection to this Agreement are free from defects and up to or exceeding industry standards, the quality and fitness for which shall be determined by PSDF.
- viii. The Company warrants and represents that it has the requisite experience of providing the Services required in connection with this Agreement.
- ix. The Company warrants and represents that it shall be legally responsible for all acts of its employees, sub-contractors, independent contractors etc. (if any) providing the Services. Provided, that the Company has taken written permission from PSDF to delegate/assign any employee/contractor the obligations of this Agreement.
- x. The execution and performance of this Agreement does not constitute a violation of any applicable laws of Pakistan and/or any agreement/understandings to which any or each of the said Parties are bound by.
- xi. The Company warrants that it possesses all requisite licenses, qualifications, certifications, registrations, regulatory approvals etc. for entering into, and performing its obligations under this Agreement.
- xii. The Company warrants and represents that there are no proceedings pending, or threatened, (i) for its dissolution or bankruptcy or (ii) that could adversely affect the performance of its respective obligations under this Agreement or the transaction contemplated hereby.
- xiii. The Company warrants and represents that it shall provide professional, objective and impartial Services and at all-time hold PSDF's interests' paramount, strictly avoid conflicts with other assignments or its own corporate interests and act without any consideration of future work.

- xiv. The Company warrants that it shall perform its obligations with all due diligence and efficiency and to the satisfaction of PSDF and shall exercise such skill and care in performance of the same in accordance with the best professional techniques, standards and practices in the training industry in engagements of similar scope, complexity and duration.
- xv. This Agreement and all documents to be executed by the Company and to be delivered to PSDF are/shall be duly authorized, registered, executed and delivered, and are/shall be legal, valid, and binding obligations of the Company.

5.2. PSDF's warranties and representations

- i. This Agreement and all documents executed or to be executed by PSDF and to be delivered to Company in connection herewith are/shall be duly authorized, executed and delivered, are legal, valid and binding obligations of PSDF enforceable in accordance with their respective terms, and do not violate the provisions of any agreement, judicial order, governmental ruling or applicable state or federal law or regulation to which PSDF is a party or to which PSDF is subjected to.

6. Indemnities and Liabilities of the Company

- 6.1. The Company shall be fully liable for the obligations arising out of or in connection with this Agreement.
- 6.2. The Company shall defend, indemnify and hold safe and harmless PSDF and its respective owners, employees, representatives and affiliates from and against any and all claims, demands, complaints or actions, including those by third parties (including employees of the Company, its subcontractors and government agencies), arising from or relating to this Agreement (including personal injury, death, property damage or damage to the environment) to the extent arising out of or in connection with any breach of this Agreement or violation of law by the Company or any contractor thereof, and including claims of or actual joint or concurrent negligence, but not including any sole or gross negligence, or willful misconduct of PSDF. The claims, demands, complaints and actions covered hereunder include but are not limited to all settlements, losses, liabilities, judgments, court costs, reasonable attorneys' fees, fines, penalties and other litigation costs and expenses arising from or related to such claims, demands, complaints or actions.

7. Indemnities and Liabilities of PSDF

- 7.1. Except for a breach of this Agreement, in no event shall PSDF be liable to the Company for any loss of profits, loss of business, interruption of business, or for indirect, special, incidental or consequential damages of any kind, even if such Company or PSDF received advance notice of the possibility of such damages.
- 7.2. The Company shall have no claim against PSDF for any liability whatsoever unless expressly provided in this Agreement. In this regard, PSDF's liability shall be excluded to the fullest extent permitted under law and to the extent it cannot be excluded under law; the maximum overall liability of PSDF shall not exceed value of the contract for any and all claims and losses.
- 7.3. PSDF shall not be responsible for any reimbursements with respect to any cost/out of the pocket expenses incurred in connection to the execution or performance of this Agreement by the Company unless agreed by PSDF in writing.

8. Events of Default and Termination

- 8.1. The following events shall each constitute an "Event of Default" by the Company and PSDF upon such Event of Default shall be entitled to forthwith terminate this Agreement without any notice:
 - i. If the Company fails to timely complete the Services or fails to provide the deliverables within the stipulated timeframes.
 - ii. If the Company fails to disclose any situation of actual or potential conflict that impacts its capacity to serve the best interest of PSDF, or that may reasonably be perceived as having such effect.
 - iii. If the Company violates or breaches, or materially fails to fully and completely observe, keep, satisfy, perform and comply with, any agreement, term, covenant, condition, requirement, restriction or provision of this Agreement and does not cure such violation, breach or failure within thirty (30) days after PSDF gives the Company written notice of such violation, breach or failure, or, if such violation, breach or failure can be cured but not within thirty (30) days with the use of diligent efforts, if the Company does not commence to cure such violation, breach or failure within such thirty (30) days period.
 - iv. If the Services provided do not conform to any requirements of PSDF and subject to the same being informed to the Company in writing the same is not replaced and/or rectified within 30 days of such intimation and/or notification.
- 8.2. PSDF reserves the right to terminate the Agreement, in whole or in part, at any point in time without assigning any reasons whatsoever with a one-month notice.

9. Entire Agreement

9.1. This Agreement, together with the Appendices A and B constitutes the entire agreement and understanding of the Parties with respect to its object and supersedes and cancels any prior representation, commitment, undertaking or agreement between the Parties, whether oral or written, with respect to or in connection with any of the matters or things to which such Agreement applies or refers.

9.1.1. the Bid Form and the Price Schedule submitted by the Supplier;

9.1.2. the Procuring Agency's Notification of Award.

9.1.3. Complete Bidding document

10. Record

10.1. The Company shall retain all the record and working papers including monthly/quarterly reports, contracts, policies/ procedures invoices, receipts and other documentary evidence in connection with the execution of this Agreement for a period of five years after the termination of this Agreement.

11. Assignment and Sub-contracting

11.1. The Company shall not assign, transfer or in any other way alienate any of its rights or obligations under this Agreement whether in whole or in part without the prior written consent of PSDF.

11.2. The Company shall not sub-contract the provisioning of the Services or any related services without the express written permission of PSDF.

12. Confidentiality

12.1. Except as otherwise permitted by this Agreement, neither of the Parties to this Agreement may disclose to third parties the contents of this Agreement or any information (other than tax advice) provided by or on behalf of the other that ought reasonably to be treated as confidential and/or proprietary.

12.2. Either Party may, however, disclose such information to the extent that it:

i. Is or becomes public other than through a breach of this Agreement;

ii. Is subsequently received by the recipient from a third party who, to the recipient's knowledge, owes no obligation of confidentiality to the disclosing party with respect to that information;

- iii. Was known to the recipient at the time of disclosure or is thereafter created independently;
- iv. Is disclosed as necessary to enforce the recipient's rights under this Agreement; or
- v. Must be disclosed under applicable law, legal process or professional regulations.

12.3. Either Party may use electronic media to correspond or transmit information and such use will not in itself constitute a breach of any confidentiality obligations under this Agreement.

13. Blacklisting

13.1. After signing the Agreement, if the Company is unable to fulfil its obligations and/or abandons the project without any cogent reason and/or commits fraud or corruption, harassment or discrimination, the Company may be blacklisted by PSDF and may be prohibited from participating in any PSDF funded schemes in the future.

14. Force Majeure

14.1. Any event or circumstances beyond the reasonable control of a Party and unavoidable by the affected Party by exercise of due care shall be deemed as an 'event of Force Majeure'. This shall include, but not be limited to, earthquakes, tsunami, fire, explosion, terrorism, storm, pandemics, flood, lightning, war and hostilities.

14.2. If either Party is affected by Force Majeure it shall forthwith notify the other party of the nature and extent thereof.

14.3. Neither Party shall be deemed to be in breach of this Agreement, or otherwise be liable to the other, by reason of any delay in performance, or non-performance, of any of its obligations under this Agreement to the extent that such delay or non-performance is due to any Force Majeure of which it has notified the other Party, and the time for performance of that obligation shall be extended accordingly.

15. Notices

15.1. A notice or other communication under or in connection with this Agreement shall be:

- (a) in writing;
- (b) in the English language; and

delivered personally, sent by courier or transmitted by email to the Party to which it is intended to be delivered.

15.2. Addresses:

PSDF	COMPANY/CONTRACTOR/FIRM
21-A, H Block, Dr. Mateen Fatima Road, Gulberg II, Lahore	ADDRESS

16. Severability

16.1. In the event that any provision of this Agreement shall be found to be void or unenforceable, such findings shall not be construed to render any other provision of this Agreement either void or unenforceable, and all other provisions shall remain in full force and effect unless the provision(s) that is/are invalid or unenforceable shall substantially affect the rights or obligations granted to or undertaken by either Party.

17. Variations

17.1. No variation of this Agreement shall be effective unless in writing and signed by or on behalf of all the Parties.

18. Intellectual Property and Data Protection

18.1. All Services provided by the Company for the purposes of this Agreement shall be considered to be commissioned works provided during the course of this Agreement for PSDF and shall be the intellectual property of PSDF solely and nothing in this Agreement shall construe that the Company is either in whole or a joint owner of any of the materials produced.

18.2. The Company may use the intellectual property of PSDF only for the purpose of this Agreement, subject to the express, written consent of PSDF. However, it may not sub-license the intellectual property to any other entity or persons nor shall the Company share the works with any third party during or after the term of this Agreement.

18.3. The Company shall in no event make use of any Intellectual Property right of PSDF including trademark, copyright, logo, patent and design or any other material without prior written approval of PSDF. The Company shall in no event represent itself as owner or licensee or assignee of the said intellectual property rights.

18.4. Any and all data, intellectual property provided by PSDF to the Company shall at all times remain the property of PSDF. The Company shall not disclose any part of the data to any third party, unless as permitted under this Agreement and the Company shall

ensure that it complies with all applicable data protection laws while dealing with the data. All data and Confidential Information provided by PSDF to the Company under this Agreement shall be immediately returned or destroyed upon the termination of this Agreement, or as instructed by PSDF. PSDF shall have the right to immediately terminate this Agreement and claim any damages in the case of any default of this Clause 18 by the Company.

18.5. The Company affirms and agrees that any information including but not limited to data files stored at its designated premises by PSDF shall remain the sole property of PSDF and nothing in this Agreement shall construe as giving any right on intellectual property, Confidential Information or any data to the Company.

19. Counterparts

19.1. This Agreement may be entered into in any number of counterparts and by the Parties to it on separate counterparts and each of the executed counterparts, when duly exchanged or delivered, shall be deemed to be an original, but taken together, they shall constitute one and the same instrument.

20. Amendments

20.1. Any amendment to this Agreement shall only be binding if executed in writing by the Parties through their duly authorized representatives.

21. Arbitration and Governing law

21.1. This Agreement shall be governed by, construed and enforced in accordance with the laws of the Pakistan and the Parties consent and submit to the jurisdiction and service of process to the courts in Lahore.

21.2. . The Parties shall attempt, in good faith, to resolve any dispute arising out of this Agreement, within five (05) business days, following the receipt by one Party of a written notice of such dispute from the other Party. In case the Parties are unable to resolve the dispute of this Agreement, the same shall be referred to mediation in accordance with this Agreement.

21.3. If the Parties are unable to resolve the dispute within such period of five (05) business days, the dispute shall be referred to mediation, to be conducted by the CEOs, or other officers authorized to act as such, of the respective Party (hereinafter the "Mediators").

The Mediators shall have ten (10) business days to negotiate, in good faith, and to resolve the dispute.

21.4. If the aforementioned informal dispute resolution procedure does not resolve the dispute within the stipulated timeline, the dispute shall finally be resolved by arbitration, in accordance with the provisions of the Arbitration Act 1940 (hereinafter the “Act, 1940”) or its successive law.

21.5. The Parties agree that in all other disputes, differences and questions in respect of any matter under this Agreement, whether during the term of this Agreement, or any renewals thereof, or after the expiry of this Agreement, arising between them may be referred to arbitration as stipulated in the Arbitration Act 1940 as amended from time to time.

22. Harassment

22.1. The Company is expected to treat all persons with whom it interacts or whom it engages for the purpose of providing the Services, with respect and dignity. No worker shall be subjected to corporal punishment, abuse of power, threats, violence, intimidation, or harassment of any kind under the applicable laws.

23. Discrimination

23.1. In the process of providing the Services, the Company shall not engage in discrimination based on race, colour, biological sex, nationality, religion, any type of disability or physical characteristics, marital status, sexual orientation, gender identity, social class and age.

24. Anti-Bribery and Anti-Corruption

24.1. The Company shall ensure that the Company, the Company’s personnel and any other person responsible for providing and performing the Services are in compliance with all anti-corruption and anti-bribery laws, and will remain in compliance with all such laws during the term of this Agreement.

24.2. PSDF shall have the right to terminate this Agreement if the Company breaches this Clause 24.

25. Waiver

25.1. Neither the failure by either Party to insist on any occasion upon the performance of the terms, conditions and provisions of this Agreement, nor time or other indulgence granted by one Party to the other, shall act as a waiver of such breach or acceptance of any variation or the relinquishment of any such right or any other right hereunder, which shall remain in full force and effect.

In witness thereof, each Party has executed and delivered this Agreement as a deed on the date, which first appears above.

PSDF	INSERT COMPANY/FIRM/CONTRACTOR

Witnesses:

1.

2.

Appendix A

Scope of Services:

The **Scope of Work** includes but is not limited the following:

- The Scope of Services includes, PV modules, On-Grid inverters (efficiency 98% or above), junction boxes, AC, DC distribution boards and cables, DC & AC Earthing, Lightening Arrestors with complete scope, communication interface, Remote Monitoring, Electrical Up-gradation where required and any other equipment necessary for safe and efficient operation of the system. Client will be responsible for the upgradation of Sanction Load.
- Successful bidder shall submit System drawing with Layout out plan and SLD, Design calculation for PV mounting structure with stud analysis is required for approval from the Engineer in-Charge before start of the work. As built drawing should be provided by the contractor after completion of work.
- The scope of Services also includes interconnection of installed PV System with the national grid, Synchronization with Existing Generator Sets. Genset Controller, ATS must be installed by the successful bidder.
- Comprehensive insurance, storage & in transit transportation is also the responsibility of successful bidder.
- The site clearance & civil works required for installation of complete system is in scope of successful bidder.
- To install the Solar PV modules, minimum size of PCC 1:2:4 concrete of size 14" x 14"x 12" (Inches) would be paved on which structure for solar PV modules will be screwed. Proper civil work will be done so as to cater wind speed of up to 150 km/hr.
- The scope of Services should also include operation and maintenance of the Solar Power Generation System for the period of **One (01) year** and the contractor also responsible to be guide/trained the maintenance staff. Whereas, the Construction duration of the Solar Power System will be of **03 months**.
- Prior to installation, **05%** quantity of Solar PV Panels will be tested by the contractor from CERAD.

- The scope of supply should also include essential spares necessary for operation, routine maintenance and testing of equipment supplied for agreed time period.
- All the equipment offered should conform in all respects to high standards/approved standards of engineering, design and workmanship and be capable of performing in commercial operation.
- All the fittings and accessories that might not have been mentioned specifically in the specification but are necessary for equipment's of the plant, should be deemed to be included in the scope of specification and shall be supplied and furnished by the installer without any extra charges.
- Successful Bidder must obey the guideline given by the Management of the respective department.
- It should be responsibility of the successful Bidder to ensure all the works as per scope of the specification in safe and efficient way, following safety standards.
- The PSDF management is authorized to interpret during installation and authorized to verify equipment, detailed drawings, specification and should have the power to reject any work or materials, which in his judgment are not in full accordance therewith.
- Roof stability Certificate along with Load Bearing Test and Hammer Test from third party must be submitted by the successful bidder.
- 1:2:4 concrete block testing via certified lab/UET Lab should be submitted by the successful bidder. Sample for block must be sealed and jointly signed & stamped by the Client/Consultant and Contractor. The strength of block must achieve 2800 psi (If applicable).
- Genset Synchronized Compatible Inverters should be installed having efficiency of 98% or above.
- Factory Acceptance Test must be provided by the successful bidder. Supply material must be tested by UET Lab. Structure should be Hot-Dip Galvanized.

- 4-core AC wire from Meter to Inverter Distribution Box (DB), if required, must be provided by the successful bidder. All the cables provided by the successful bidder must be of approved standards.
- Internet device package must be valid with provision of uninterrupted internet till the entire duration of the O&M period (12-Months) of the project.
- The procuring agency may ask the successful bidder to provide sample at any stage for the clarification purpose and the successful bidder must provide a complete electrical tool kit at site for O&M purpose including all necessary equipment along with First Aid Kit.
- Complete Net-Metering process of the installed Solar System must be the responsibility of the successful bidder. PSDF will nominate its focal person for the Net-Metering process that assist the Contractor/Successful bidder for completing the process timely. Net-metering application must be in the name of Point of Contact (POC) nominated by PSDF whereas, the process must be the responsibility of bidder.
- Sanction Load upgradation will be the responsibility of Client.
- Warranty Documents (provided by manufacturer/vendor) must be provided by the successful bidder along with As-Built documents at the time of completion of the project.

Solar PV system should consist of following equipment:

- i. The proposed Solar Based Power Generation System should comprise of minimum **KW** as provided in Solar Potential column.
- ii. The accumulative capacity of Efficient Grid Tie Inverters should be **equal or greater the solar PV capacity** and array combination. It shall depend on the contractor whether to offer single or a combination of multiple inverters.
- iii. Mounting structures (roof mounted or elevated)
- iv. Cables (AC/DC) and hardware provided as per approved standards/specifications.
- v. Civil/ Mechanical Works
- vi. Miscellaneous Item
 - a. Remote Monitoring and Data Logging

- b. Synchronization Hardware.
 - c. Junction box and distribution boxes
 - d. ATS (Automatic Transfer Switch)
 - e. Earthing kit / Protection devices
 - f. Lightning arrestors
 - g. PVC pipes and accessories
 - h. Tool kit, etc.
- vii. It is recommended that the bidder must visit the site before the preparation of technical bid.

**Appendix B
Payment Terms**

Summary of Prices:

Project Description	Total Cost of Solar Equipment PKR	Total Cost of Services (Excluding O&M) PKR	Total Cost of O&M (01 years) PKR	Total Cost of Spare Parts	Total Cost of the Project PKR
Design, Supply, Installation, Testing & Commissioning along with (01) years Operation & Maintenance for the project					
Total Price Inclusive of all Applicable Taxes =					

Payment Milestone:

Sr. #	Payment Milestone/Deliverables/ Deliverables	Percentage
1.	Survey & Design Approval	5%
2.	Site Preparation (Clearance of Roof, Civil work for PV Mounting Structure)	5%
3.	Supply and Installation of PV Mounting/Elevated Structure	10%
4.	Submission of approved Sample Test Reports of PV Modules, Block Test Reports, Wire Test Reports and Conduits Pipe tests.	5%
5.	Supply of PV Modules and Inverter	15%
6.	Installation of Solar Modules at Site	10%

7.	Installation of Inverter along with Genset Controller, AC Cables, DC Cables and Earthing.	20%
9.	Complete commissioning on Site and upon Installation of Site; real time as well as Online Monitoring Access.	15%
10.	Rectification of Punch List duly verified by the Consultant.	5%
11.	Upon installation of Bi-Directional Meter and submission of Net-Metering Application to DISCO as per NEPRA rules and submission of Final Report after successful completion of the Project duly verified by the Consultant.	10 %
Total		100%

Note:

- In case of difference between unit price and total price, unit price shall prevail, and total price shall be “final”. *(Please refer ITB clause 2.5.6).*
- In case of difference between amount in “words” and amount in “figures”, amount in “words” shall be considered final.

Payment Terms:

- Payment shall be made in Pak. Rupees in the following manner:
 - Running Bill modality.
- PSDF shall be entitled to increase or decrease the quantity of required BOQ. Moreover, the quantity will be finalized at the time of signing the contract and the above-mentioned quantities are just for the evaluation purpose.
- All the payments shall be made in PKR after applying all the applicable taxes.

Penalties:

The Supplier affirms and acknowledges that any delay in the delivery of the Products will result in a penalty applicable to the Supplier. The penalty shall be one (1%) percent per day, not exceeding a total of ten (10%) of the total value of the Agreement. Such penalty shall be deductible from the amount secured as a Performance Guarantee / invoice from the Supplier.

- 1% per day delay upto 10% of contract value.

8.10. Financial Bid Form/Price Schedule

[To be signed & stamped by the Bidder and reproduced on the letter head. To be attached with Financial Bid]

Summary of Prices:

Project Description	Total Cost of Solar Equipment PKR (Inclusive of Taxes)	Total Cost of Services (Excluding O & M) PKR (Inclusive of Taxes)	Total Cost of O&M (01 years) PKR (Inclusive of Taxes)	Total Cost of Spare Parts (Inclusive of Taxes)	Total Cost of the Project PKR (Inclusive of Taxes)
Design, Supply, Installation, Testing & Commissioning along with (01) years Operation & Maintenance for the project					
Total Cost Inclusive of all Applicable Taxes in Figures =					
Total Cost Inclusive of all Applicable Taxes in Words =					

Schedule of Prices – Summary of Bid Prices:

[To be signed & stamped by the Bidder and reproduced on the letter head. To be attached with along with Financial Bid]

BILL OF QUANTITY (BOQ)							
						Inclusive of all applicable Taxes	
Sr. No.	Items Name	Specification	Brand	Unit	Quantity	Unit Price	Total Price
1	Imported Equipment						
1.1	Solar Panel	560-585 Watts	JA N Type or Equivalent	Watt	50310		

1.1	String Inverter	Grid Tie Inverter 50 KTL with Dongle	Huawei or Equivalent	No.	1.00			
2	Mechanical And Civil Work							
2.1	Mounting Structure	Roof Top Structure Elevated HDG with civil work		Watt	50310			
3	Cables and Conductors							
3.1	DC cable - Red	4 sq.mm, 1C, PVC/PVC, Rated 1000V	Newage/FAST or Equivalent	Meter	350			
	DC cable - Black	4 sq.mm, 1C, PVC/PVC, Rated 1000V	Newage/FAST or Equivalent	Meter	350			
3.3	AC cable	35 sq.mm, 3.5C, PVC/PVC, Rated 600/1000 V	Newage/FAST or Equivalent	Meter	10			
3.4	Grounding Cable (Panels)	Green Color Single Core Flexible 2.5 sq.mm, CU/PVC	Newage/FAST or Equivalent	Meter	30			
3.5	Grounding Cable (Structure)	Green Color Single Core Flexible 2.5 sq.mm, CU/PVC	Newage/FAST or Equivalent	Meter	20			
	Grounding Cable (Inverters)	Green Color Single Core Flexible 35 sq.mm, CU/PVC	Newage/FAST or Equivalent	Meter	10.00			
3.6	Bare Conductor	6/10/25 sq.mm	Newage/FAST or Equivalent	Meter	10.00			
3.7	Communication Cable	Beldon Cable RS485		Meter	30			
4	Electrical Equipment and Miscellaneous Items							
4.1	LV Panel	Outdoor rated, equipped with 1 x 125 Amp 4 Pole. Contain all standard accessories and bus bar capable to hold 400 Amps current and earthing bus bar accordingly,		No.	1.00			

		Floor mounted type, with Key lock. RYB indication. On/off/trip indication.	Local or Equivalent				
4.2	Lightning Arresters			No.	2.00		
4.3	PVC Pipe	4" With Accessories		Meter	40.00		
4.4	PVC Pipe	2" With Accessories		Meter	30.00		
4.5	Cable tray with cover and accessories	Pre galvanized 300x150 MM 14 SWG		Meter	40.00		
4.6	MC4 Connector	Male + female		Pairs	10.00		
4.7	Consumable Items	Lugs, thimble, shrouds, etc.		Lot	50310		
5	Earthing						
5.1	Earthing Pits	As per site requirement		No.	3.00		
5.2	Ground Copper Electrode	Copper strip/Rod		No.	3.00		
6	Services						
6.1	Installation Works	Project Design & Execution					
		Mounting Structure Installation					
		Solar Panel installation		Watt	50310		
		Electrical Wiring and Equipment Installation					
6.2	Transportation Services			Watt	50310		
6.3	Lodging ,Traveling, Project Management, Installation Supervision,			Watt	50310		

	Commissioning Services.						
6.4	<p>Net-Metering Process for installed system (including all equipment, Load Flow Study (if applicable), Fee, Approvals, Documentation, Bi-Directional Meter, Inspection).</p> <p>Zero Export Device must be installed during the Net-Metering procedure.</p> <p>Note: Total price must include all applicable fees mandatory for Net-Metering</p>			Watt	50310		
6.5	Operations and Maintenance "O&M Services (01 Years)			Watt	50310		
Grand Total =							

Note:

- In case of difference between unit price and total price, unit price shall prevail, and total price shall be "final". *(Please refer ITB clause 2.5.6).*
- In case of difference between amount in "words" and amount in "figures", amount in "words" shall be considered final.

Payment Terms:

- Business shall be awarded based on Least Cost Selection Method.
- Payment shall be made in Pak. Rupees in the following manner:
 - Running Bill modality.
- PSDF shall be entitled to increase or decrease the quantity of required BOQ. Moreover, the quantity will be finalized at the time of signing the contract and the above-mentioned quantities are just for the evaluation purpose.
- All the payments shall be made as per actual in PKR after applying all the applicable taxes.

Penalties:

The Supplier affirms and acknowledges that any delay in the delivery of the Products will result in a penalty applicable to the Supplier. The penalty shall be one (1%) percent per day, not exceeding a total of ten (10%) of the total value of the Agreement. Such penalty shall be deductible from the amount secured as a Performance Guarantee / invoice from the Supplier.

- 1% per day delay upto 10% of contract value.

Stamp & Signature of Bidder _____

8.11. Bid Security Form

(Applicable in case of Bank Guarantee only)

[To be signed & stamped by the Bidder and reproduced on the letter head. To be attached with Financial Bid]

Whereas [name of the Bidder] (hereinafter called "the Bidder") has submitted its Bid dated [date of submission of Bid] for the supply of [name and/or description of the goods] (hereinafter called "the Bid").

KNOW ALL PEOPLE by these presents that WE [name of bank] of [name of country], having our registered office at [address of bank] (hereinafter called "the Bank"), are bound unto [name of Procuring Agency] (hereinafter called "the Procuring Agency") in the sum of for which payment well and truly to be made to the said Procuring Agency, the Bank binds itself, its successors, and assigns by these presents. Sealed with the Common Seal of the said Bank this ____ day of _____ 20____.

THE CONDITIONS of this obligation are:

1. If the Bidder withdraws its Bid during the period of Bid validity specified by the Bidder on the Bid Form; or
2. If the Bidder, having been notified of the acceptance of its Bid by the Procuring Agency during the period of Bid validity:
 - (a) fails or refuses to execute the Contract Form, if required; or
 - (b) fails or refuses to furnish the Performance Guarantee, in accordance with the Instructions to Bidders;

we undertake to pay to the Procuring Agency up to the above amount upon receipt of its first written demand, without the Procuring Agency having to substantiate its demand, provided that in its demand the Procuring Agency will note that the amount claimed by it is due to it, owing to the occurrence of one or both of the two conditions, specifying the occurred condition or conditions.

This guarantee will remain in force up to and including sixty (60) days after the period of Bid validity, and any demand in respect thereof should reach the Bank not later than the above date.

[Signature of the bank]

8.12. Proposed Program of Works

[To be signed & stamped by the Bidder and reproduced on the letter head. To be attached with Technical Bid]

Bidder shall provide a program in a bar-chart/CPM/PERT form showing the sequence of work items by which he proposes to complete the work of the entire Contract. The program should indicate the sequence of work items and the period of time during which he proposes to complete the Works including the activities like designing, schedule of submittal of drawings, ordering and procurement of materials, manufacturing, delivering, construction of civil works, erection, testing and commissioning of Works to be supplied under the Contract.

8.13. Method of Performing Works

[To be signed & stamped by the Bidder and reproduced on the letter head. To be attached with Technical Bid]

The bidder is required to submit a narrative outlining the method of performing the Works. The narrative should indicate in detail and include but not be limited to:

The sequence and methods in which he proposes to carry out the Works, including the number of shifts per day and hours per shift, he expects to work.

A list of all major items of constructional and erection plant, tools and vehicles proposed to be used in carrying out the Works at Site, including number of each kind, make, type, capacity of all equipment, working condition, which shall be deployed by him for Civil Work and Erection, Testing and Commissioning of the Works, in sufficient detail to demonstrate fully that the equipment will meet all the requirements of the Technical Provisions.

The procedure for installation of equipment and transportation of equipment and materials to the site.

Details regarding mobilization in Pakistan, the type of facilities including personnel accommodation, office accommodation, provision for maintenance and for storage, communications, security and other services to be used.

Organization chart indicating head office & field office personnel involved in management, supervision and engineering of the Works to be done under the Contract.

Section IX- Check List

[To be signed & stamped by the Bidder and reproduced on the letter head. To be attached with Technical Bid]

The provision of this checklist is essential prerequisite along with submission of tenders (with technical proposal).

Sr. #	Detail	Responsive	Non-responsive
1	Bid Security of 0.5% i.e., Rs. 39,219/- (Thirty-Nine Thousand Two Hundred Nineteen Rupees) in the form of a pay-order or demand draft favoring Punjab Skills Development Fund shall reach to PSDF, Procurement Department on 21 A, H-Block, Dr. Mateen Fatima Road, Gulberg II, Lahore – Pakistan before the opening of the bid (Please mention the title of the procurement on envelope). If original bid security is not delivered before the opening of the bid, the bidder shall be disqualified for further proceeding. The Bid Security should be valid for a period not less than 6 months and a scanned copy must be attached in the financial envelope of the e-tendering portal.		
2	Active Registration with Income Tax Authorities (National Tax Number NTN), as per the Evaluation Criteria		
3	Copy of active Registration with Sales Tax Authorities (STRN), as per the Evaluation Criteria		
4	Bid Form (as per form 8.1 of Bidding documents) on letter head of the firm, duly signed and stamped.		
5	Bidder Profile Form (as per form 8.4 of Bidding documents) on letter head of the firm, duly signed and stamped.		
6	General Information Form (as per form 8.5 of Bidding documents) on letter head of the firm duly signed and stamped.		
7	Affidavit (as per form 8.6 of Bidding documents) on non-judicial Stamp Paper of not less than Rs. 100/- duly attested by Oath Commissioner . Original affidavit must be delivered to PSDF office as per the mentioned address before the closing date and submission time of the bid.		
8	Technical Bid Form (as per form 8.8 of Bidding documents) on letter head of the firm duly signed and stamped.		
9	Financial Bid Form (as per form 8.10 of Bidding documents) on letter head of the firm, duly signed and stamped.		
10	Copy of certificate of incorporation/company registration		

	certificate/ firm registration certificate.)		
11	Declaration on letterhead that bidder is not participating as Joint venture.		

Stamp & Signature of Bidder _____